

# WASHTENAW COUNTY ROAD COMMISSION TRAFFIC SIGNAL DETAILS

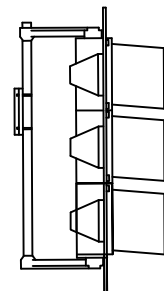
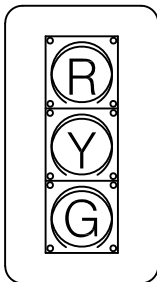
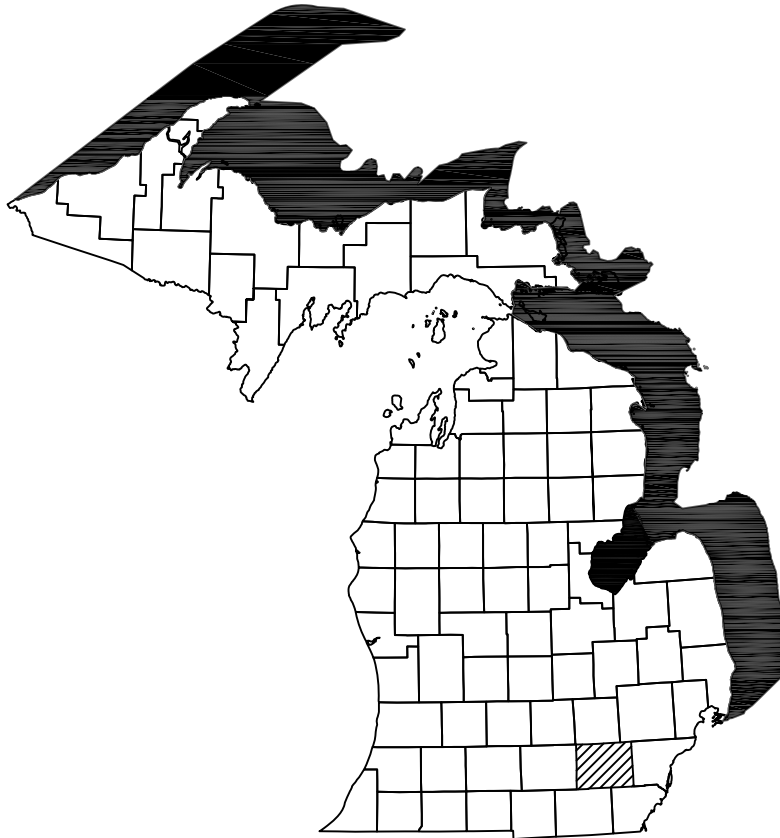
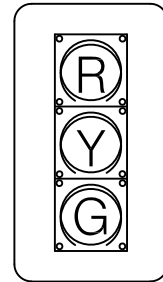
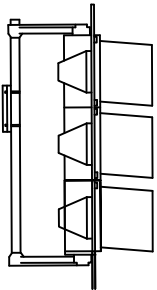

## SHEETS INDEX

- COVER SHEET (THIS SHEET)
- WASH TSN - TRAFFIC SIGNAL NOTES (1 PAGE)
- WASH 1 - SPAN WIRE TRAFFIC SIGNAL INSTALLATION ON STEEL POLES (4)
- WASH 2 - SINGLE SPAN WIRE TRAFFIC SIGNAL INSTALLATION ON WOOD POLES (2)
- WASH 3 - SECONDARY SERVICE WOOD POLE WITH DISCONNECT BOX (1)
- WASH 4 - SINGLE (DOUBLE) TRAFFIC SIGNAL TO WOOD POLE FIT UP (1)
- WASH 5 - REMOVED
- WASH 6 - FLASHING BEACON SINGLE SPAN WIRE ON WOOD POLES (2)
- WASH 7 - TRAFFIC SIGNAL ANTENNA MOUNTING (1)
- WASH 8 - TERMINAL BLOCK WIRING CONNECTIONS (Color Coded) OF THE PEDESTRIAN AND VEHICULAR TRAFFIC SIGNAL (2)
- WASH 9 - PHASING DIAGRAM (1)
- WASH 10 - BASE MOUNTED TRAFFIC SIGNAL CONTROLLER FOUNDATION & CABINET/ SIDE OF POLE SIGNAL/DIGITAL LOOP DETECTOR/CONTROLLER CABINET (4)
- WASH 11 - TEMPORARY TRAFFIC SIGNAL CONTROLLER CABINET (1)
- WASH 12 - BRACKET ARM MOUNTED TRAFFIC AND PEDESTRIAN SIGNALS (4)
- WASH 13 - TRAFFIC SIGNAL HANDHOLE (1)
- WASH 14 - CONDUIT TRENCH (1)
- WASH 15 - TRAFFIC SIGNAL LOOP (SAWCUT) (1)
- WASH 16 - TRAFFIC SIGNAL MAST ARM STANDARD & ARM DETAILS CATEGORY III (6)
- WASH 17 - REMOVED
- WASH 18 - PEDESTRIAN PEDESTAL, FOUNDATION & BRACKETING (1)
- WASH 19 - RRFB WIH MAST ARM STD & PEDESTRIAN PEDESTAL (4)
- WASH 20 - UNINTERRUPTIBLE POWER SUPPLY STANDARD WIRING DIAGRAM (1)

APPROVED BY J.P.Y.

REVISION DATE: 03/15/2024

COVER SHEET

1 OF 1



555 N. ZEEB RD.  
ANN ARBOR, MI 48103-1556  
734-761-1500

1. ALL EXISTING STREET LIGHTING, TRAFFIC SIGNAL, PRIMARY, TRANSMISSION, ETC., CIRCUITS SHALL ALWAYS BE MAINTAINED IN OPERATIONAL CONDITION (EXCEPT WHERE NOTED).
2. EXISTING TRAFFIC SIGNAL AND OVERHEAD FACILITIES ARE NOT NECESSARILY SHOWN ON THE PLANS.
3. ALL OVERHEAD WIRES AND UNDERGROUND CABLES SHALL CONSIST OF COPPER CONDUCTORS AS PER SPECIFICATIONS.
4. ALL WIRES AND CABLES SHALL BE TAGGED IN A PERMANENT MANNER INDICATING THE SOURCE AND USE OF EACH. THIS SHALL BE DONE IN ALL HANDHOLES AND CABINETS WHERE THESE WIRES AND CABLES ENTER, EXIT, ARE SPLICED, AND ARE TERMINATED.
5. SUFFICIENT CABLE SHALL BE COILED IN HANDHOLE IN ORDER TO EXTEND 2 FT. ABOVE THE SURFACE OF THE GROUND.
6. ALL TRAFFIC SIGNALS SHALL BE MOUNTED WITH NEW STANDARD TRAFFIC SIGNAL BRACKETS AND FITTINGS.
7. ALL TRAFFIC SIGNAL HEADS SHALL BE 12-INCH INDICATIONS AS SHOWN ON PLAN, AND CONSTRUCTED OF POLYCARBONATE MATERIAL.
8. SEAL END OF CABLE WHERE COILING OF CABLE IS CALLED FOR ON THE PLANS.
9. A MINIMUM CLEARANCE OF 3'-6" HORIZONTAL, AND 1'-0" VERTICAL MUST BE MAINTAINED BETWEEN PROPOSED FACILITIES AND EXISTING UNDERGROUND WATER FACILITIES.
10. NEW TRAFFIC SIGNAL HEADS AND CASE SIGNS SHALL BE KEPT BAGGED PRIOR TO OPERATION, OR UNTIL OTHERWISE DIRECTED BY THE ENGINEER. THE PRICE FOR BAGGING TRAFFIC SIGNAL HEADS AND CASE SIGNS WILL BE INCLUDED IN THE LUMP SUM PRICE BID FOR THE TRAFFIC SIGNAL.
11. ALL CONDUIT BENDS SHALL HAVE A MINIMUM RADII IN ACCORDANCE WITH THE CURRENT N.E.C.
12. ALL TRAFFIC SIGNAL FITTINGS (SCREWS, NUTS, BOLTS, PINNACLES, ETC.) SHALL BE GREASED WITH A NON-OXIDE TYPE GREASE.
13. NO CHANGES FROM THE PLANS IN THE LOCATION OF SUPPORTING STRUCTURES, SIGNAL HEAD PLACEMENT, OR TRAFFIC CONTROL EQUIPMENT WILL BE ALLOWED WITHOUT PRIOR APPROVAL BY THE WASHTENAW COUNTY ROAD COMMISSION, TRAFFIC AND SAFETY SECTION, ANN ARBOR, MI. PHONE: (734) 761-1500.
14. FIT-UP STEEL POLE AS A TRAFFIC SIGNAL CABLE POLE SHALL INCLUDE FURNISHING AND INSTALLING GROUND ROD AND CLAMP, GROUND WIRE, CONCRETE ENCASED CONDUIT BEND(S) IN POLE FOUNDATION, WEATHER HEAD AND LINE HARDWARE AS SHOWN ON THE PLANS AND SPECIAL DETAILS, ALL FOR A COMPLETE OPERATING JOB. THIS WILL NOT BE PAID SEPARATELY, BUT WILL BE CONSIDERED AS INCLUDED IN THE LUMP SUM PRICE BID FOR THE TRAFFIC SIGNAL.
15. ALL JACK-BORED, OPEN CUT, OR DIRECT BURIAL CONDUIT CALLED FOR ON THE PLANS IS THE PREFERRED METHOD OF INSTALLATION. IF THE CONTRACTOR PREFERENCES TO USE ANY OTHER METHOD, THE CHANGE OF METHOD MAY BE MADE UPON APPROVAL BY THE PROJECT ENGINEER.
16. THE CONTRACTOR IS RESPONSIBLE FOR DETERMINING OR ANTICIPATING THE NEED OR DESIRE TO INSTALL THE CONDUIT BY ANY OTHER METHOD AND INCLUDING THE COST IN THE CONTRACT UNIT PRICE BID.
17. NO EXTRA PAYMENT WILL BE ALLOWED FOR ANY CHANGE IN THE METHOD OF CONDUIT INSTALLATION.
18. THE TRAFFIC SIGNAL SHALL BE INSTALLED IN ACCORDANCE WITH THE MICHIGAN MANUAL OF UNIFORM TRAFFIC CONTROL DEVICES (M.M.U.T.C.D.).
19. ALL CONDUITS, FITTINGS, AND BENDS SHALL BE SCHEDULE 80 PVC (POLYVINYL CHLORIDE) IN ACCORDANCE WITH THE NATIONAL ELECTRIC CODE. CONDUITS, FITTINGS AND BENDS SHALL BE APPROVED FOR ABOVE GROUND AND UNDERGROUND USE, SUNLIGHT RESISTANCE, AND FOR 90 DEGREE CENTIGRADE RATED CABLE.
20. TRAFFIC SIGNAL ASSEMBLIES SHALL BE INSPECTED BY THE WASHTENAW COUNTY ROAD COMMISSION, TRAFFIC AND SAFETY SECTION, PRIOR TO INSTALLATION ON THE TRAFFIC SIGNAL SPAN WIRE OR MAST ARM.
21. THE CONNECTION OF THE TRAFFIC SIGNAL CONTROLLER TO THE 120V DETROIT EDISON SERVICE SHALL INCLUDE FURNISHING AND INSTALLING A 2-CIRCUIT, 60 AMP WEATHER PROOF DISCONNECT BOX, CONDUIT RISER, CONDUIT BODY AT BASE OF POLE, NECESSARY FITTINGS, WEATHER HEAD, PIPE CLAMPS AND WOOD/PLASTIC MOLDING AS SHOWN ON THE PLANS AND SPECIAL DETAILS. THIS WILL NOT BE PAID FOR SEPARATELY, BUT WILL BE CONSIDERED AS INCLUDED IN THE LUMP SUM PRICE BID FOR THE TRAFFIC SIGNAL.
22. PEDESTRIAN SIGNALS SHALL BE DIRECTED TOWARD THE CENTER OF THE CURB DROP FOR THE CROSSWALK THEY CONTROL.
23. TIMING OF THE TEMPORARY CONTROLLER, AND INTERIM AND PERMANENT TIMING OF THE MAIN CONTROLLER SHALL BE PERFORMED BY THE WASHTENAW COUNTY ROAD COMMISSION.
24. INSTALLATION OF THE TEMPORARY CONTROLLER SHALL INCLUDE INSTALLING NEW OR USED GROUND WIRE, GROUND ROD AND CLAMP, CONDUIT RISER, CONDUIT BODIES AND FITTINGS, WEATHER HEAD, PIPE CLAMPS, AND WOOD/PLASTIC MOLDING AS SHOWN ON THE PLANS AND SPECIAL DETAILS. THIS WILL NOT BE PAID FOR SEPARATELY, BUT WILL BE CONSIDERED AS INCLUDED IN THE LUMP SUM UNIT PRICE BID FOR TRAFFIC SIGNAL, REMOVE AND SALVAGE.
25. ALL CONDUIT PLACED UNDER THE ROADWAY VIA JACK AND BORE METHOD, SHALL HAVE A MINIMUM COVER OF 48" BELOW THE TOP OF PAVEMENT SURFACE FOR LOCAL ROADS AND 60" FOR PRIMARY ROADS.
26. THE DIFFERENCE IN HEIGHT BETWEEN THE CENTER OF ALL RED SIGNAL LENSES SHALL BE LESS THAN 6".
27. THE MAXIMUM DISTANCE BETWEEN HAND HOLES SHALL BE 150 FEET.
28. CONDUIT OPENINGS IN THE CABINETS SHALL BE BLOCKED BY TIGHTLY PACKING STEEL WOOL A MINIMUM OF 6 INCHES DEEP FOR RODENT CONTROL.
29. BASE MOUNT CABINETS SHALL BE CAULKED INSIDE, OUTSIDE, AND UNDER CABINET.
30. WEATHERHEADS SHALL BE NETTED. NETTING WILL BE PROVIDED BY W.C.R.C.

	555 N Zeeb Rd Ann Arbor, MI 48103  734-761-1500		Initials	Date	<h2 style="margin: 0;">TRAFFIC SIGNAL NOTES</h2>	Page 1 of 1
		Created by	JDM	09/2003		
		Revised by	RLH	10/02/2023		
		Approved by	JPY	10/02/2023		
		WASH-TSN				

SEE TRAFFIC SIGNAL AND CASE SIGN INSTALLATION ON SPAN WIRE DETAIL (WASH-1, PAGE 4)

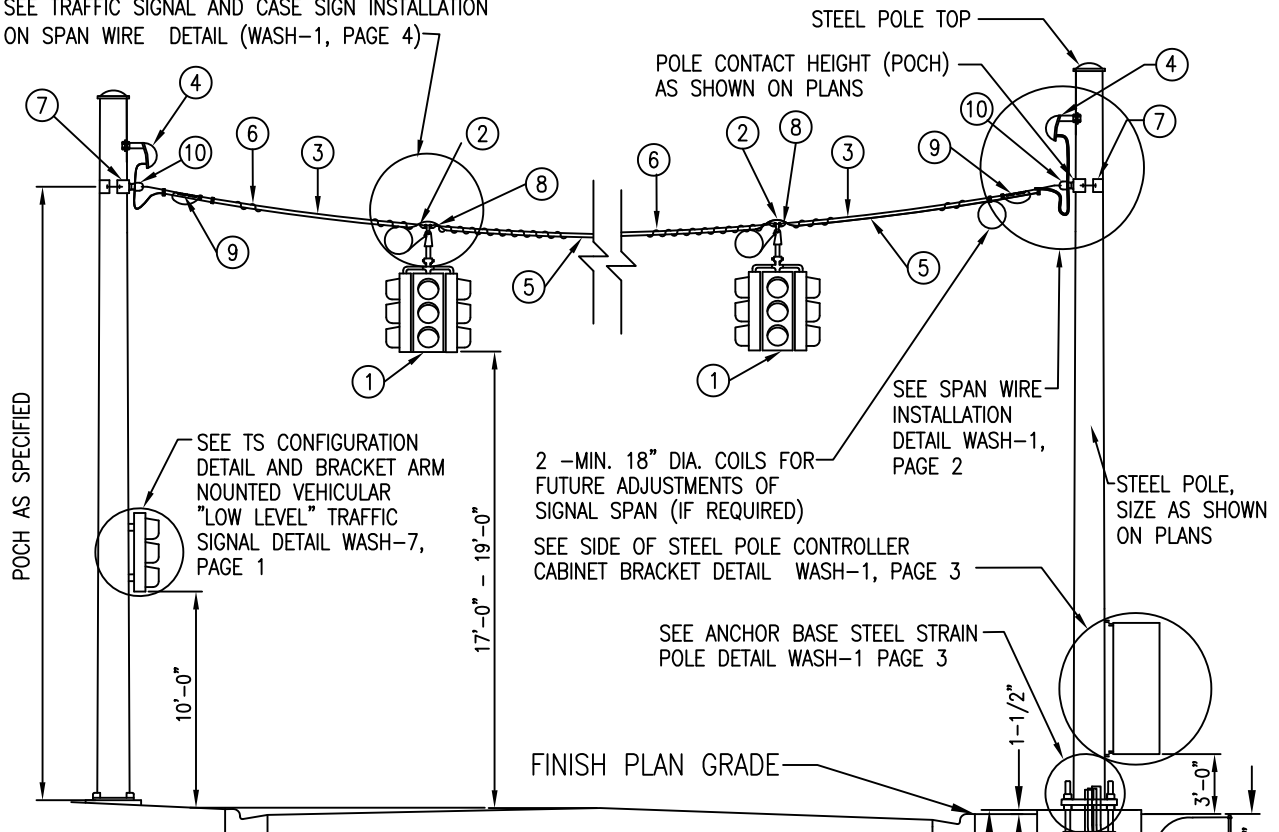

No.	ITEM
1.	TRAFFIC SIGNAL HEADS (No. & TYPE AS INDICATED)
2.	SPAN WIRE HANGER
3.	*5/16" EXTRA HIGH STRENGTH SPAN WIRE
4.	3" SERVICE CAP (WEATHERHEAD, NETTED)
5.	P.J. TRAFFIC SIGNAL CABLE(S) (AS SPECIFIED)
6.	PREFORMED LASHING RODS
7.	SPAN WIRE CLAMP
8.	INSTALL SPAN WIRE PREFORMED (ARMOR ROD) UNDER EACH SPAN HANGER
9.	WIRE CLIPS OR PREFORMED GUY GRIP DEAD ENDS
10.	CARRIAGE BOLT, OVAL EYE NUT AND THIMBLE

NOTES:

- \* DIFFERENCE IN ELEVATIONS BETWEEN THE CENTER OF RED SIGNAL LENSES MUST BE LESS THAN SIX (6) INCHES.
- \* DIFFERENT SIGNAL ARRANGEMENTS, SUCH AS FIVE SEPARATE HEADS W/CASE SIGN, MAY BE REQUIRED. SEE PLAN DETAILS FOR SPECIFIC ARRANGEMENTS.
- \* ALL TRAFFIC SIGNAL INSTALLATION SHALL CONFORM TO THE MICHIGAN MANUAL OF UNIFORM TRAFFIC CONTROL DEVICES, OR AS DIRECTED BY THE ENGINEER.
- \* ALL GROUNDS SHALL PROVIDE LESS THAN 10 OHM RESISTANCE TO GROUND.
- \* WEATHERHEADS SHALL BE NETTED (NETTING PROVIDED BY WCRC).

2 -MIN. 18" DIA. COILS FOR FUTURE ADJUSTMENTS OF SIGNAL SPAN (IF REQUIRED)  
 SEE SIDE OF STEEL POLE CONTROLLER CABINET BRACKET DETAIL WASH-1, PAGE 3  
 SEE ANCHOR BASE STEEL STRAIN POLE DETAIL WASH-1 PAGE 3

1-1 1/2" & 2-3" CONDUIT 90° SWEEP ON 36" RADIUS  
 ANCHOR BOLTS (TYPICAL) SEE MDOT DETAIL SIG-40-A  
 35S CONCRETE  
 BOLT TIE ROD (TYPICAL) SEE MDOT DETAIL SIG-40-A

ANCHOR BOLTS WITHIN 3" TO 12" OF BOTTOM

3/4" X 10'-0" COPPER CLAD GROUND ROD(S)



555 N Zeeb Rd Ann Arbor, MI 48103 734-761-1500	Initials	Date
	Created by JDM	09/2003
	Revised by RLH	10/06/2023
	Approved by JPY	10/06/2023

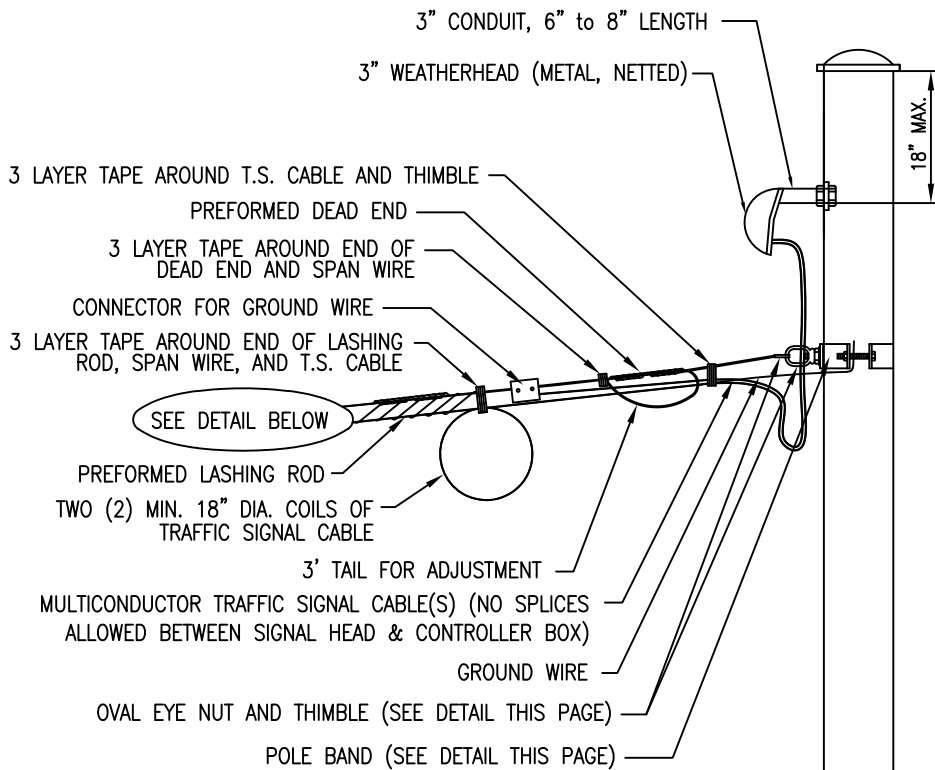

SEE DETAIL BELOW

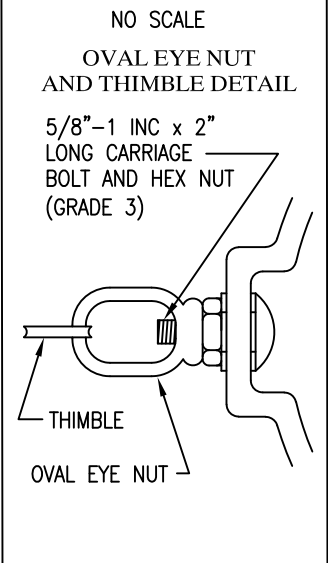
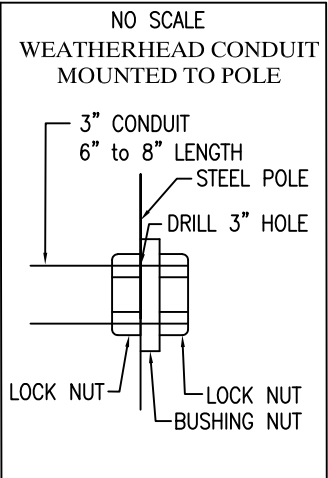
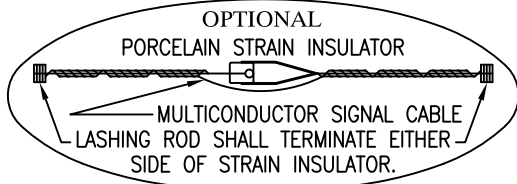

POLE BAND DETAIL  
(ASTM A36 STEEL)

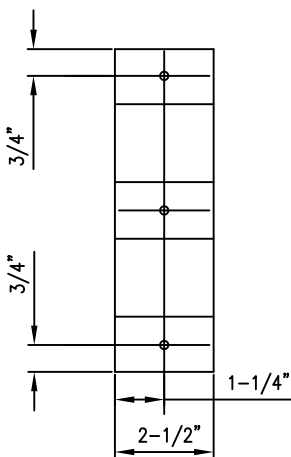

ELEVATION

TWO (2) 5/8"–1 INC x 2–3/4" LONG  
HEX HEAD BOLT, LOCK WASHER,  
FLAT WASHER AS REQ'D, AND HEX NUT  
(A325 GALVANIZED)

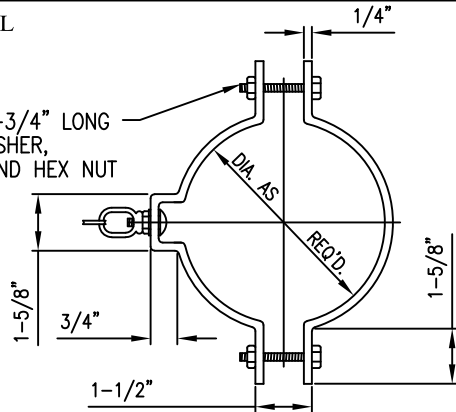

PLAN



555 N Zeeb Rd  
Ann Arbor, MI 48103  
734-761-1500

	Initials	Date
Created by	JDM	09/2003
Revised by	RLH	10/06/2023
Approved by	JPY	10/06/2023

SPAN WIRE TRAFFIC SIGNAL  
AND WEATHERHEAD  
INSTALLATION TO STEEL POLES

WASH-1

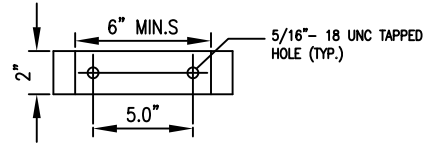
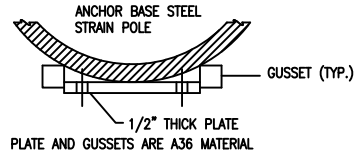

CABINET MOUNTING BRACKET DETAIL C

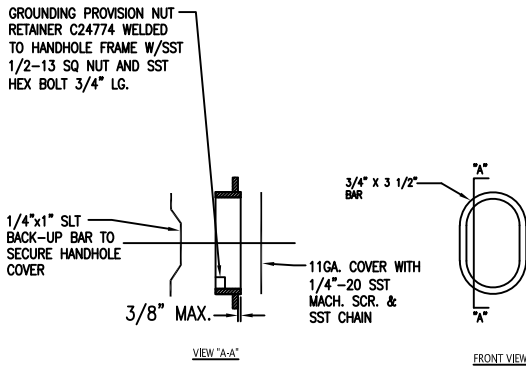

6" x 10" BAR HANDHOLE DETAIL

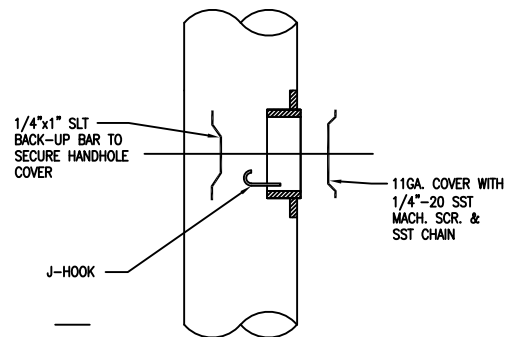

4" x 6 1/2" BAR HANDHOLE DETAIL

DETAIL C

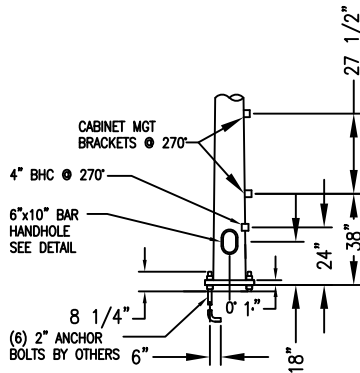

BASE DETAIL WITH DETECTOR CABINET

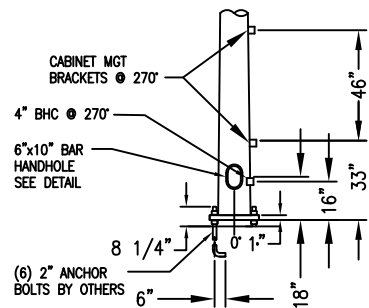

BASE DETAIL WITH CONTROLLER CABINET



555 N Zeeb Rd  
Ann Arbor, MI 48103  
734-761-1500

	Initials	Date
Created by	JDM	09/2003
Revised by	RLH	10/06/2023
Approved by	JPY	10/06/2023

SPAN WIRE STEEL POLE  
HANDHOLE, CABINET BRACKET &  
POLE BASE DETAILS

WASH-1

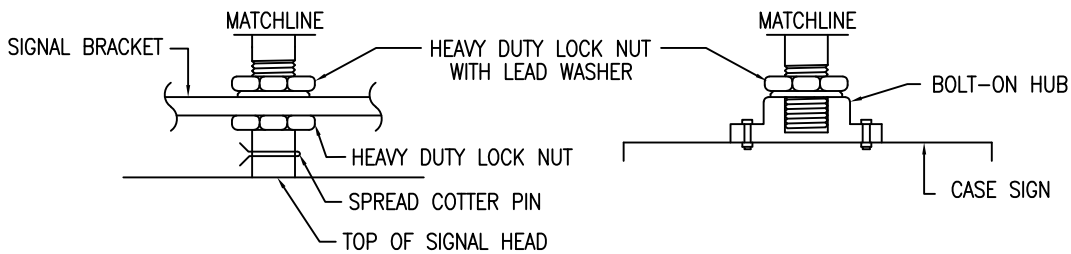
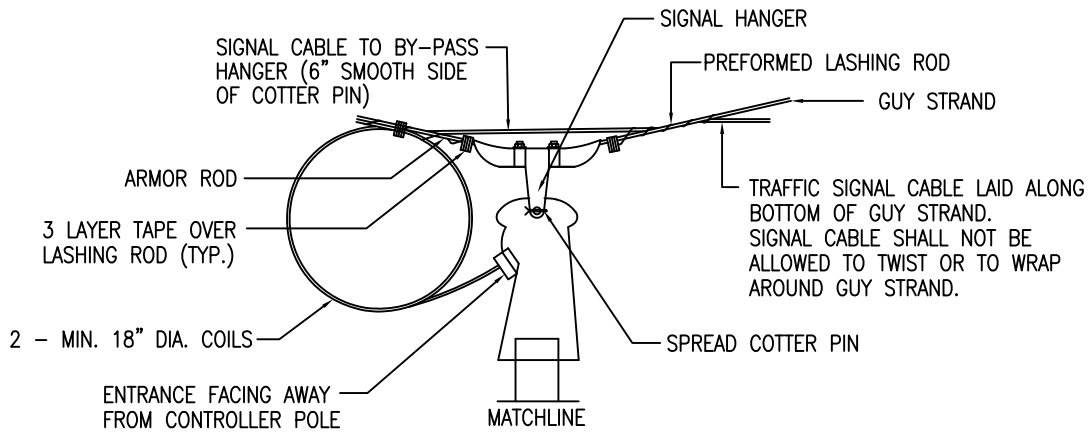

555 N Zeeb Rd  
Ann Arbor, MI 48103  
734-761-1500

	Initials	Date
Created by	JDM	09/2003
Revised by	RLH	10/06/2023
Approved by	JPY	10/06/2023

SEE TRAFFIC SIGNAL AND CASE SIGN INSTALLATION ON SPAN WIRE DETAIL (WASH-1, PAGE 3)

POLE CONTACT HEIGHT (POCH) AS SHOWN ON PLANS

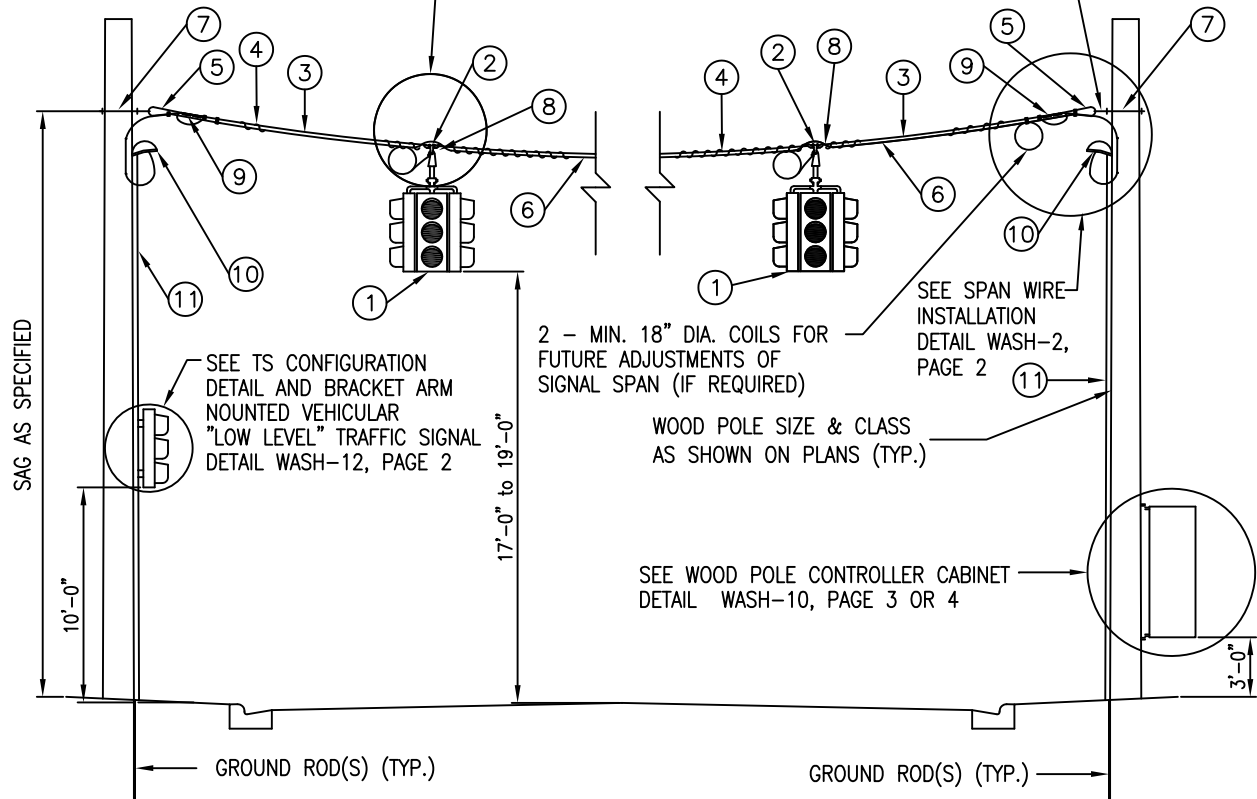

No.	ITEM
1.	TRAFFIC SIGNAL HEADS (No. & TYPE AS INDICATED)
2.	SPAN WIRE HANGER
3.	*5/16" EXTRA HIGH STRENGTH SPAN WIRE
4.	PREFORMED LASHING RODS
5.	*GUY THIMBLE
6.	P.J. TRAFFIC SIGNAL CABLE (AS SPECIFIED)
7.	*5/8" EYEBOLT
8.	INSTALL SPAN WIRE PREFORMED (ARMOR ROD) UNDER EACH SPAN HANGER
9.	*PREFORMED GUY GRIP DEAD ENDS
10.	3" SERVICE CAP (WEATHERHEAD, NETTED)
11.	3" PVC (SCHEDULE 80)

NOTES:  
NO SCALE

DIFFERENCE IN ELEVATIONS BETWEEN THE CENTER OF RED SIGNAL LENSES SHALL BE LESS THAN SIX (6) INCHES.

DIFFERENT SIGNAL ARRANGEMENTS, SUCH AS FIVE SEPERATE HEADS W/CASE SIGN, MAY BE REQUIRED. SEE PLAN DETAILS FOR SPECIFIC ARRANGEMENTS.

ALL TRAFFIC SIGNAL INSTALLATION SHALL CONFORM TO THE MICHIGAN MANUAL OF UNIFORM TRAFFIC CONTROL DEVICES, OR AS DIRECTED BY THE ENGINEER.

\* BY POWER COMPANY



555 N Zeeb Rd  
Ann Arbor, MI 48103  
734-761-1500

	Initials	Date
Created by	JDM	09/2003
Revised by	RLH	10/06/2023
Approved by	JPY	10/06/2023

SPAN WIRE TRAFFIC SIGNAL  
INSTALLATION ON WOOD POLES

WASH-2

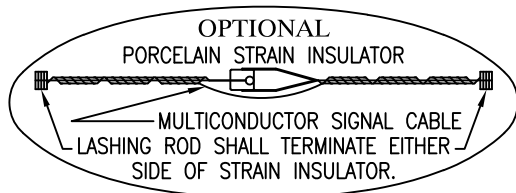
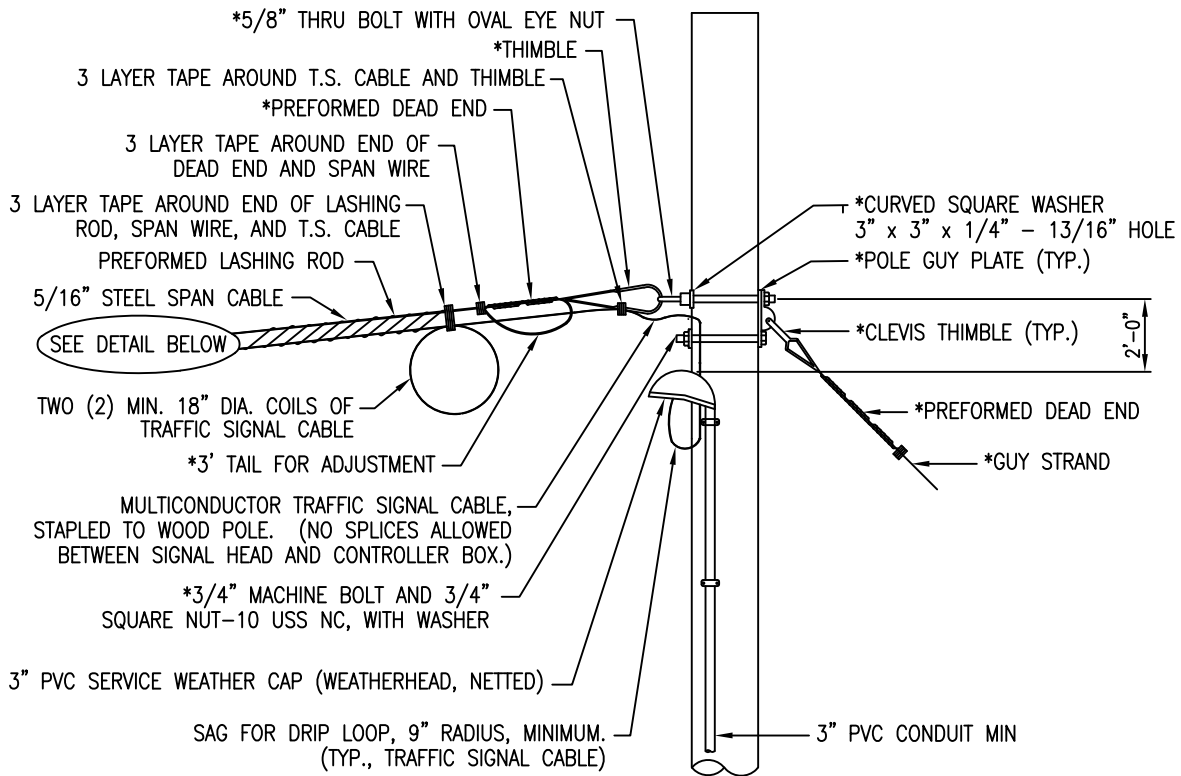

NOTES:  
NO SCALE

ALL CONDUIT SHOWN SHALL BE SCHEDULE 80 PVC (POLYVINYLCHLORIDE). UNLESS OTHERWISE SPECIFIED OR DIRECTED BY THE ENGINEER.

THERE IS NO GAP BETWEEN THE 5/16" STEEL CABLE SPAN AND THE MULTICONDUCTOR TRAFFIC SIGNAL CABLE. THE LASHING ROD MUST HOLD THE TWO TOGETHER.

\* BY POWER COMPANY



555 N Zeeb Rd  
Ann Arbor, MI 48103  
734-761-1500

	Initials	Date
Created by	JDM	09/2003
Revised by	RLH	10/06/2023
Approved by	JPY	10/06/2023

SPAN WIRE INSTALLATION  
ON WOOD POLE

WASH-2



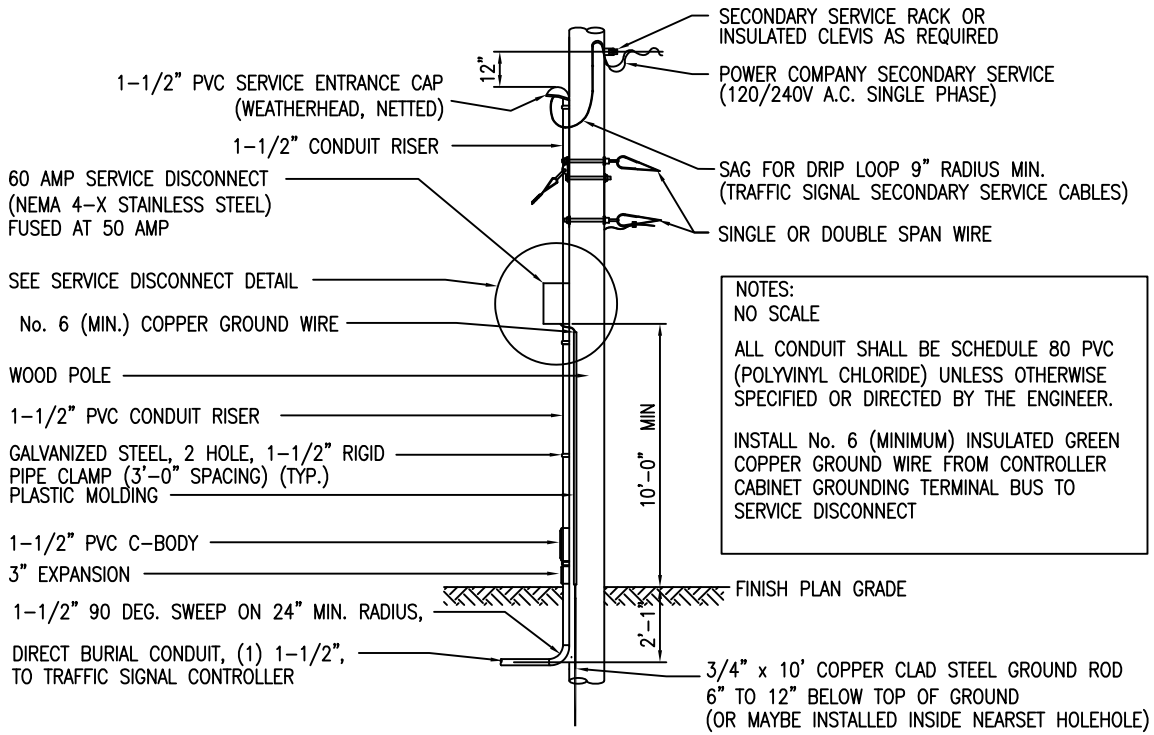

NOTES:  
 NO SCALE  
 ALL CONDUIT SHALL BE SCHEDULE 80 PVC (POLYVINYL CHLORIDE) UNLESS OTHERWISE SPECIFIED OR DIRECTED BY THE ENGINEER.  
 INSTALL No. 6 (MINIMUM) INSULATED GREEN COPPER GROUND WIRE FROM CONTROLLER CABINET GROUNDING TERMINAL BUS TO SERVICE DISCONNECT

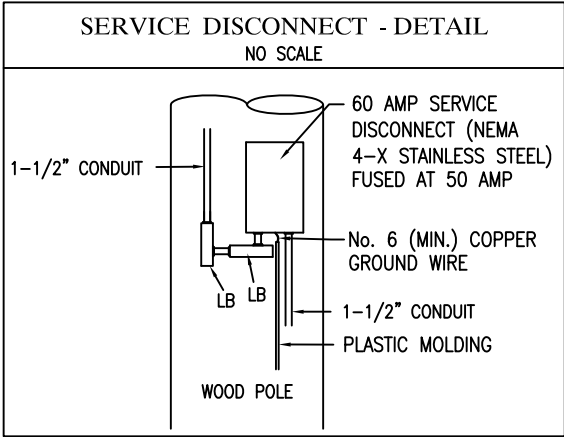
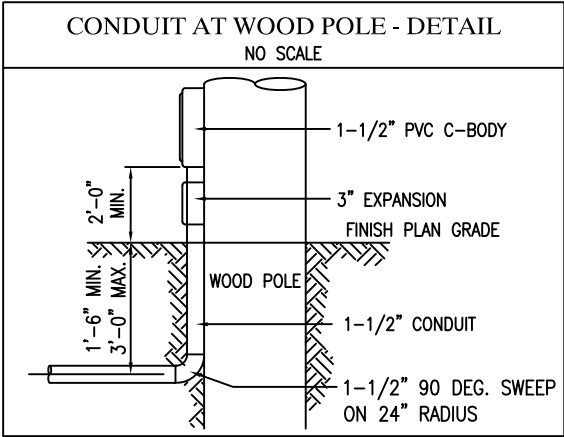

555 N Zeeb Rd  
 Ann Arbor, MI 48103  
 734-761-1500

	Initials	Date
Created by	JDM	09/2003
Revised by	RLH	10/06/2023
Approved by	JPY	10/06/2023

SECONDARY SERVICE WOOD POLE WITH  
 DISCONNECT BOX,  
 SINGLE OR DOUBLE SPAN WIRE

WASH-3

Page 1 of 1

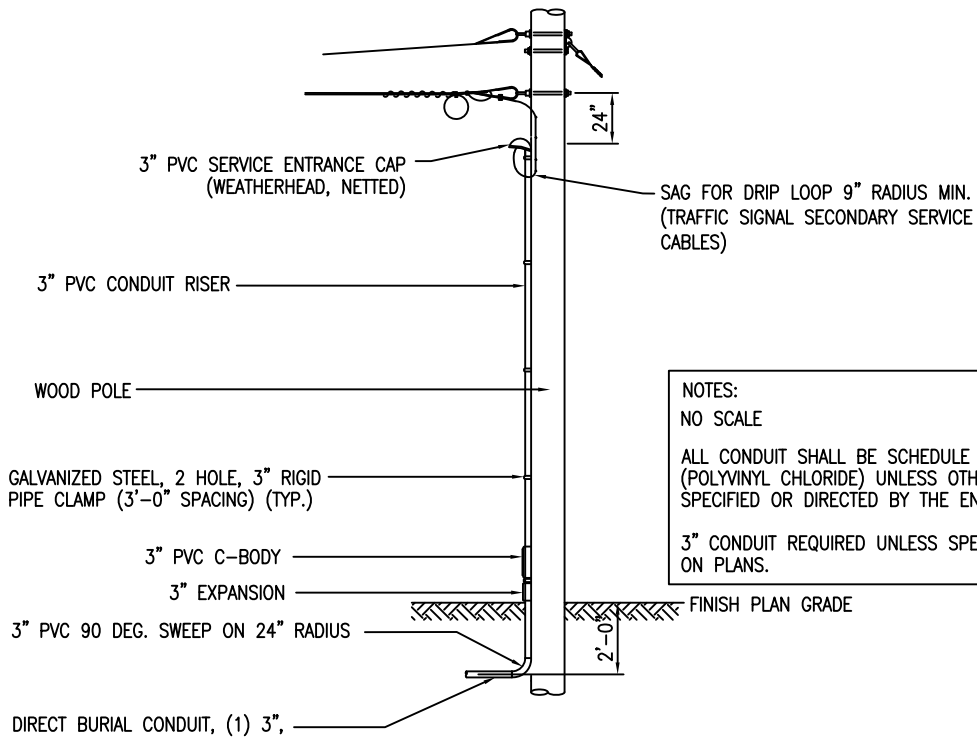

NOTES:  
 NO SCALE  
 ALL CONDUIT SHALL BE SCHEDULE 80 PVC (POLYVINYL CHLORIDE) UNLESS OTHERWISE SPECIFIED OR DIRECTED BY THE ENGINEER.  
 3" CONDUIT REQUIRED UNLESS SPECIFIED ON PLANS.

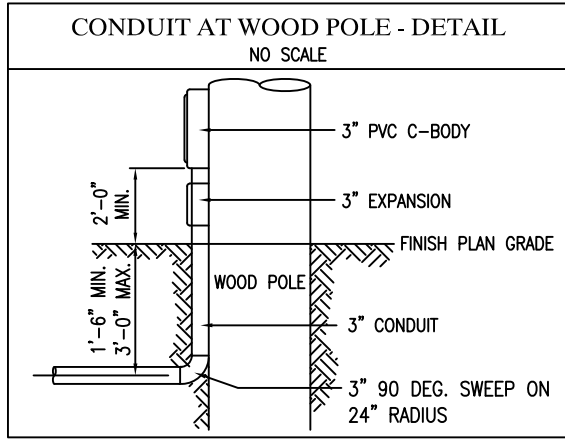

555 N Zeeb Rd  
 Ann Arbor, MI 48103  
 734-761-1500

	Initials	Date
Created by	JDM	09/2003
Revised by	RLH	10/06/2023
Approved by	JPY	10/06/2023

**SINGLE OR DOUBLE TRAFFIC SIGNAL  
 TO WOOD POLE FIT UP**

WASH-4

### FLASHING BEACON ON WOOD POLES - DETAIL

NO SCALE

SEE INSTALLATION DETAIL WASH-1, PAGE 3

POLE CONTACT HEIGHT (POCH)  
AS SHOWN ON PLANS

SEE SINGLE SPAN  
WIRE INSTALLATION  
DETAIL WASH-6,  
PAGE 2

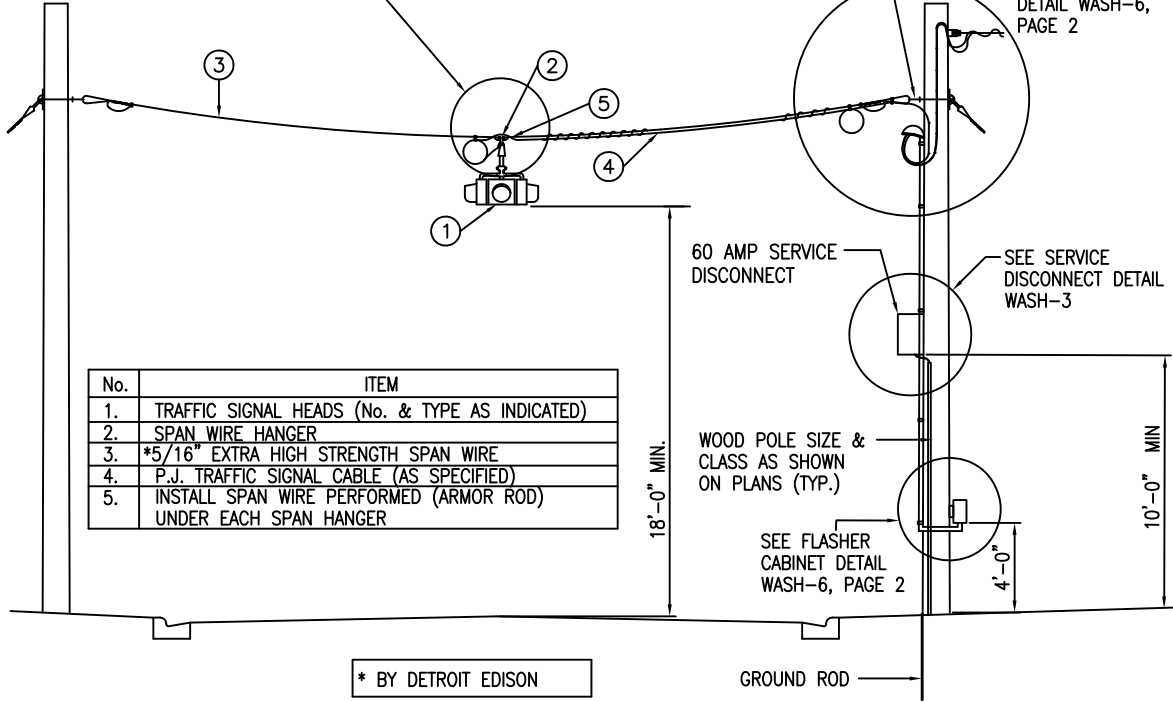

No.	ITEM
1.	TRAFFIC SIGNAL HEADS (No. & TYPE AS INDICATED)
2.	SPAN WIRE HANGER
3.	*5/16" EXTRA HIGH STRENGTH SPAN WIRE
4.	P.J. TRAFFIC SIGNAL CABLE (AS SPECIFIED)
5.	INSTALL SPAN WIRE PERFORMED (ARMOR ROD) UNDER EACH SPAN HANGER

### TWO FLASHING BEACONS ON WOOD POLES - DETAIL

NO SCALE

SEE INSTALLATION DETAIL WASH-1, PAGE 3

POLE CONTACT HEIGHT (POCH)  
AS SHOWN ON PLANS

SEE SINGLE SPAN  
WIRE INSTALLATION  
DETAIL WASH-6,  
PAGE 2

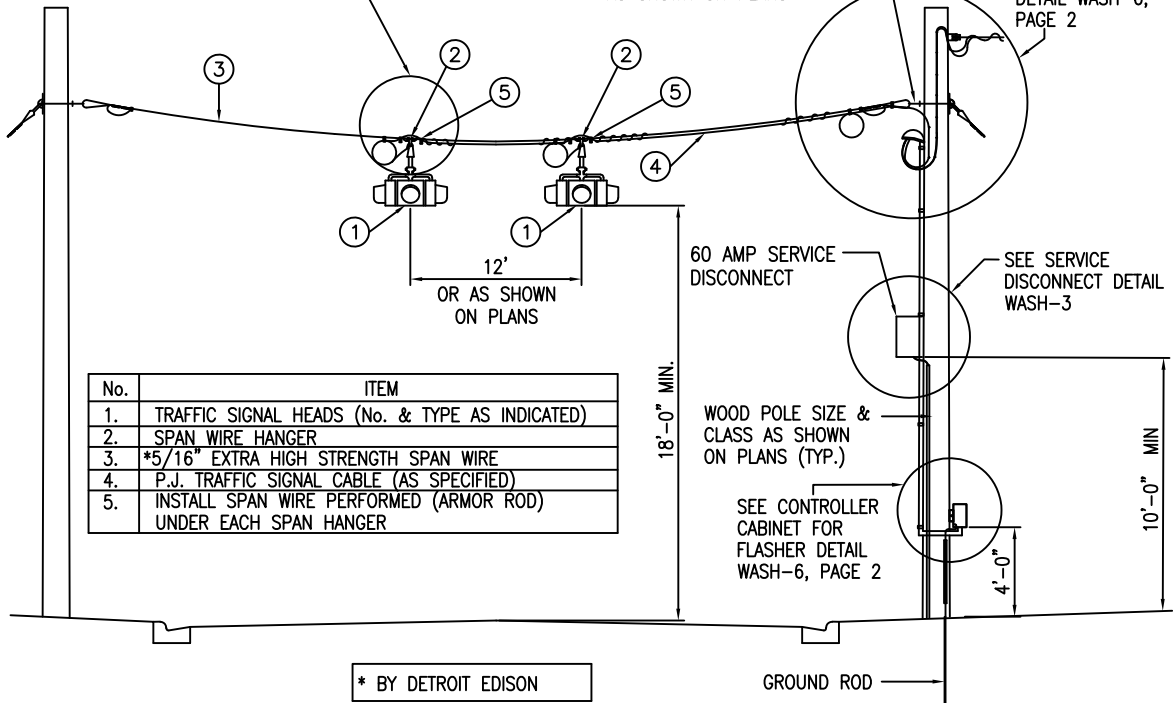

No.	ITEM
1.	TRAFFIC SIGNAL HEADS (No. & TYPE AS INDICATED)
2.	SPAN WIRE HANGER
3.	*5/16" EXTRA HIGH STRENGTH SPAN WIRE
4.	P.J. TRAFFIC SIGNAL CABLE (AS SPECIFIED)
5.	INSTALL SPAN WIRE PERFORMED (ARMOR ROD) UNDER EACH SPAN HANGER



555 N Zeeb Rd  
Ann Arbor, MI 48103  
734-761-1500

	Initials	Date
Created by	JDM	09/2003
Revised by	RLH	10/10/2023
Approved by	JPY	10/10/2023

**FLASHING BEACON INSTALLATION  
SINGLE SPAN WIRE ON WOOD POLES  
ONE SECTION TRAFFIC SIGNALS**

WASH-6

Page 1 of 2

### SPAN WIRE INSTALLATION ON WOOD POLE

NO SCALE

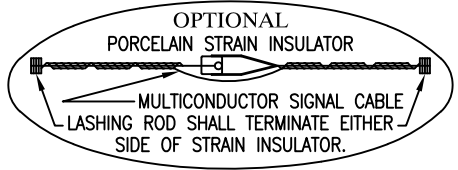
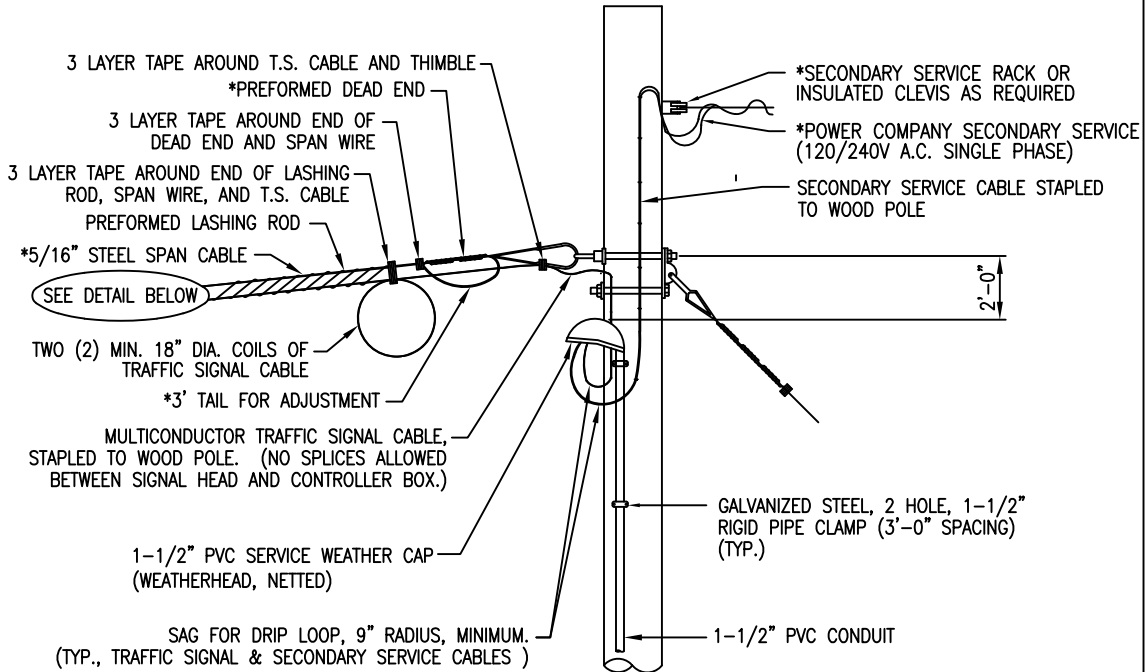

**NOTES:**  
 ALL CONDUIT SHOWN SHALL BE SCHEDULE 80 PVC (POLYVINYLCHLORIDE), UNLESS OTHERWISE SPECIFIED OR DIRECTED BY THE ENGINEER.  
 THERE IS NO GAP BETWEEN THE 5/16" STEEL CABLE SPAN AND THE MULTICONDUCTOR TRAFFIC SIGNAL CABLE. THE LASHING ROD MUST HOLD THE TWO TOGETHER.  
 \* BY POWER COMPANY

### CONTROLLER CABINET FOR FLASHER - DETAIL

NO SCALE

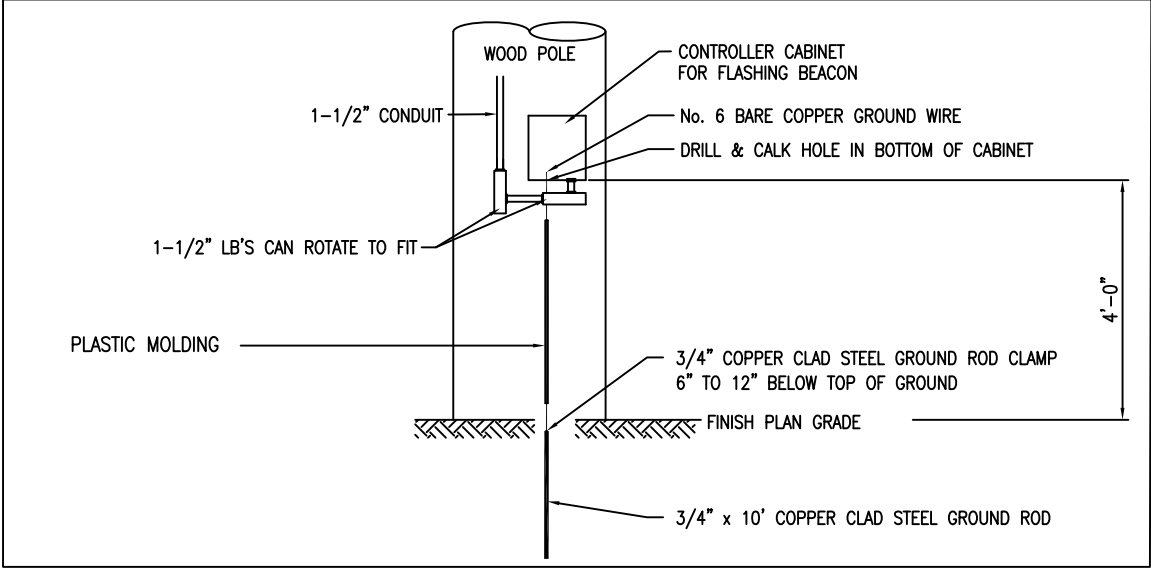

555 N Zeeb Rd  
 Ann Arbor, MI 48103  
 734-761-1500

	Initials	Date
Created by	JDM	09/2003
Revised by	RLH	10/10/2023
Approved by	JPY	10/10/2023

### FLASHING BEACON INSTALLATION SINGLE SPAN WIRE ON WOOD POLES CONTROLLER CABINET

WASH-6

# TRAFFIC SIGNAL STEEL POLE ANTENNA MOUNTINGS

## MAST ARM STD. MOUNT

## BRACKET ARM MOUNT

## MAST ARM MOUNT

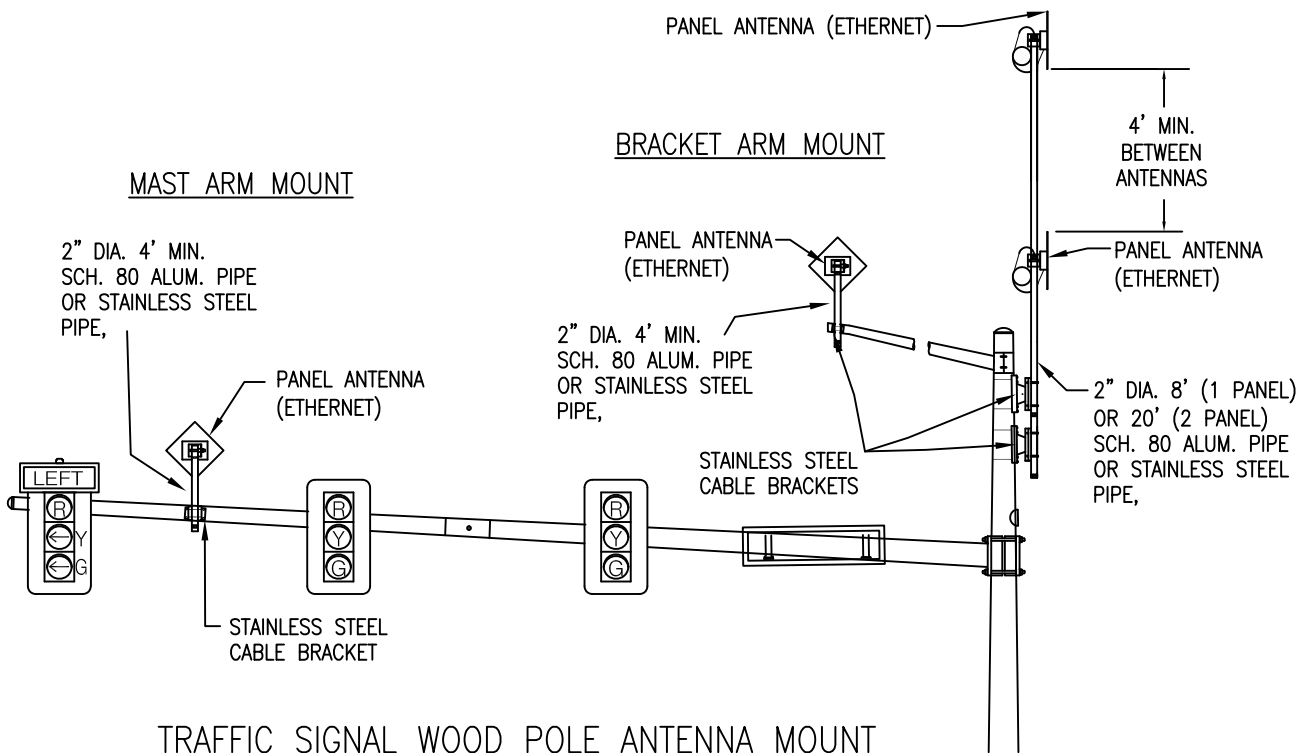

## TRAFFIC SIGNAL WOOD POLE ANTENNA MOUNT

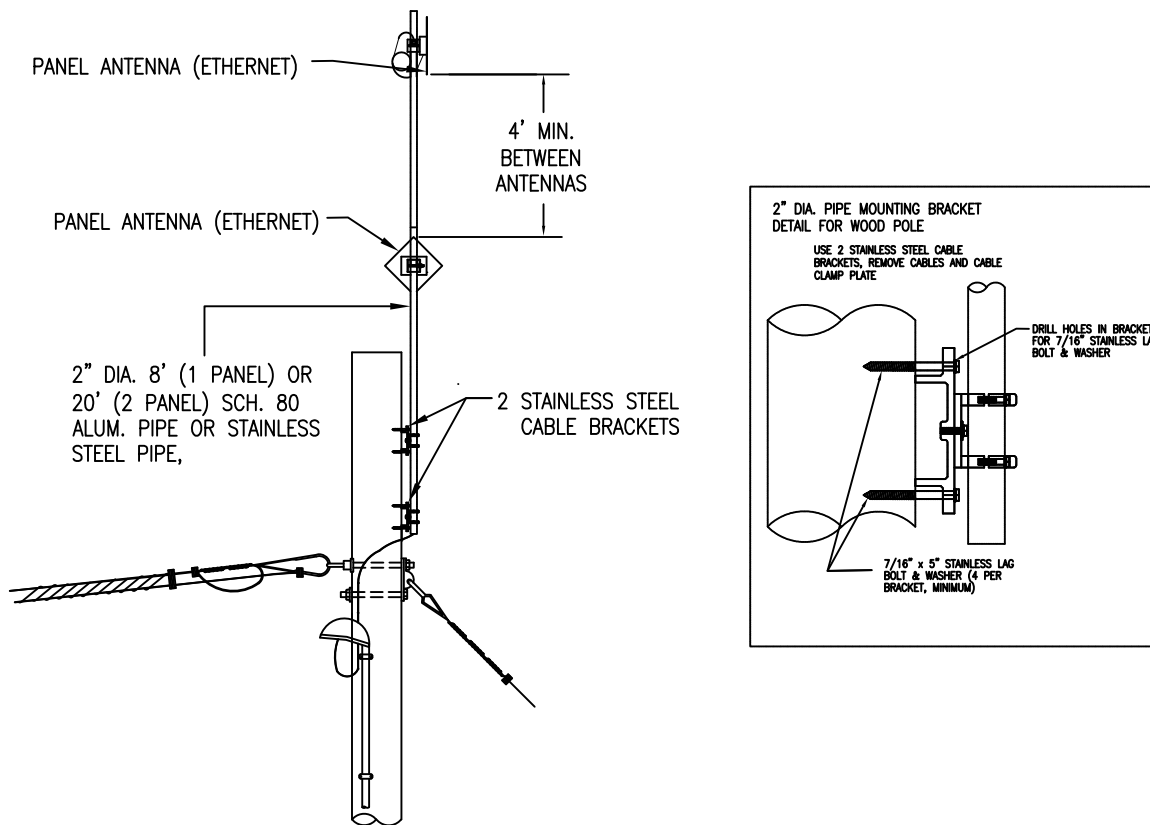

555 N Zeeb Rd  
Ann Arbor, MI 48103  
734-761-1500

	Initials	Date
Created by	JDM	09/2003
Revised by	RLH	10/10/2023
Approved by	JPY	10/10/2023

## TRAFFIC SIGNAL ANTENNA MOUNTING

WASH-7

TERMINAL BLOCK WIRING CONNECTIONS (COLOR CODED) OF THE PEDESTRIAN AND VEHICULAR TRAFFIC SIGNAL AND CASE SIGN LAMPS WITH FIELD CABLES FROM THE TRAFFIC SIGNAL CONTROLLER OR SIDE OF POLE CABINET

NO SCALE

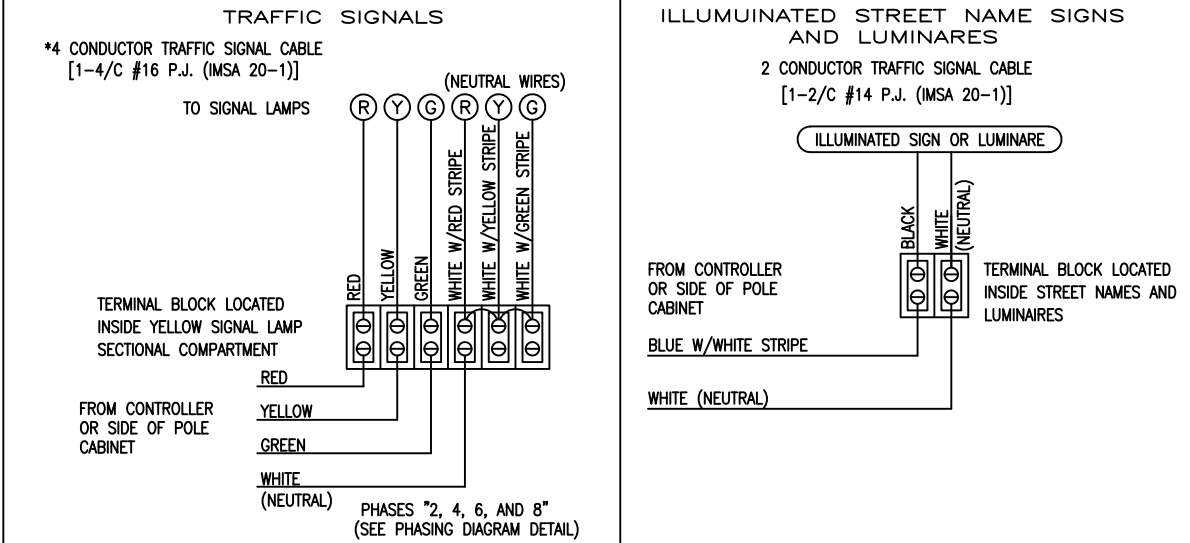
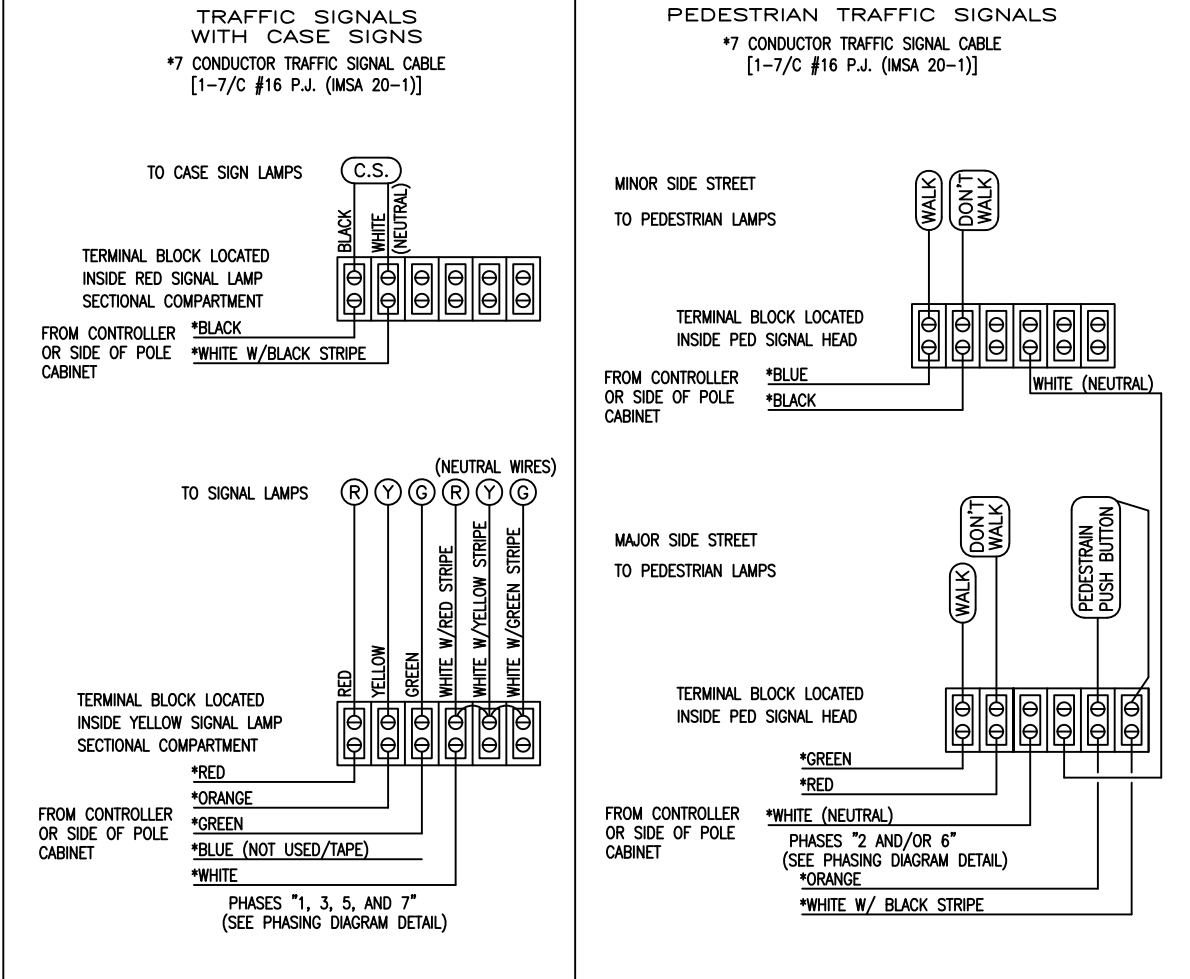

555 N Zeeb Rd Ann Arbor, MI 48103 734-761-1500	Initials	Date
	Created by JDM	09/2003
	Revised by RLH	10/10/2023
	Approved by JPY	10/10/2023

**CONTROLLER CABINET WITH SIDE OF POLE CABINETS**

**20 CONDUCTOR #14 or as approved by WCRC Engineer**

	Wire Color		
1	BLACK	CABINET POWER	
2	BLACK W/RED STRIPE	CASE SIGNS	
3	BLUE W/BLACK STRIPE	LUMINAIRES	
4	RED W/GREEN STRIPE	STREET NAME SIGNS	
5	WHITE	NEUTRAL	
6	WHITE W/BLACK STRIPE	FLASHING YELLOW ARROW (FYA)	
7	WHITE W/RED STRIPE	NEUTRAL	ALT. WHEN NEEDED RIGHT TURN RED
8	RED W/BLACK STRIPE	LEFT TURN RED	
9	ORANGE W/ BLACK STRIPE	LEFT TURN YELLOW	
10	GREEN W/ BLACK STRIPE	LEFT TURN GREEN	
11	RED	THRU RED	
12	ORANGE	THRU YELLOW	
13	GREEN	THRU GREEN	
(7)	WHITE W/RED STRIPE	RIGHT TURN RED	ALT. WHEN NEEDED RIGHT TURN RED
14	ORANGE W/RED STRIPE	RIGHT TURN YELLOW	
15	BLUE W/RED STRIPE	RIGHT TURN GREEN	
16	RED W/WHITE STRIPE	MAIN PED RED	
17	GREEN W/WHITE STRIPE	MAIN PED GREEN	
18	BLACK W/WHITE STRIPE	SIDE PED RED	
19	BLUE W/WHITE STRIPE	SIDE PED GREEN	
20	BLUE	STOP BAR RELAY	

**10 CONDUCTOR #14 or as approved by WCRC Engineer**

	Wire Color		
1	RED	RELAY OUTPUTS - LFT	
2	GREEN	RELAY OUTPUTS - ADV	
3	RED W/BLACK STRIPE	RELAY OUTPUTS - ADV	
4	GREEN W/BLACK STRIPE	RELAY OUTPUTS - ADV	
5	ORANGE	PED PUSH BUTTON MAIN ST	
6	WHITE W/BLACK STRIPE	PED PUSH BUTTON MAIN ST	
7	BLUE	LOG. GND	
8	ORANGE W/BLACK STRIPE	PED PUSH BUTTON SIDE ST	
9	WHITE	NOT USED	
10	BLACK	PED PUSH BUTTON SIDE ST	

NOTE: OPTIONAL WIRING AS DIRECTED BY WCRC ENGINEER



555 N Zeeb Rd  
Ann Arbor, MI 48103  
734-761-1500

	Initials	Date
Created by	JDM	09/2003
Revised by	RLH	10/10/2023
Approved by	JPY	10/10/2023

**CONTROLLER CABINET WIRING CONNECTIONS  
(COLOR CODED) WITH SIDE POLE CABINETS**

WASH-8

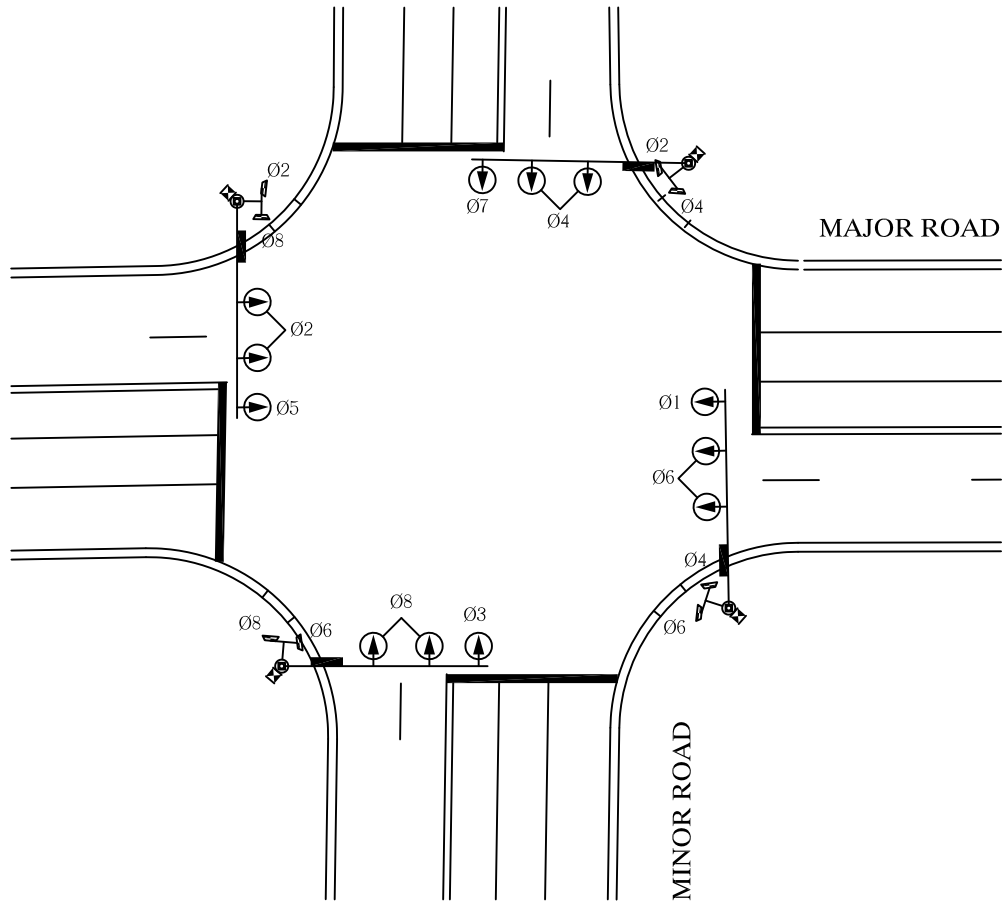

NOTES:  
 A MORE DETAILED PHASING DIAGRAM WILL BE  
 PROVIDED AT THE PRECONSTRUCTION MEETING  
 NO SCALE



555 N Zeeb Rd  
 Ann Arbor, MI 48103  
 734-761-1500

	Initials	Date
Created by	JDM	09/2003
Revised by	RLH	10/06/2023
Approved by	JPY	10/06/2023

PHASING DIAGRAM



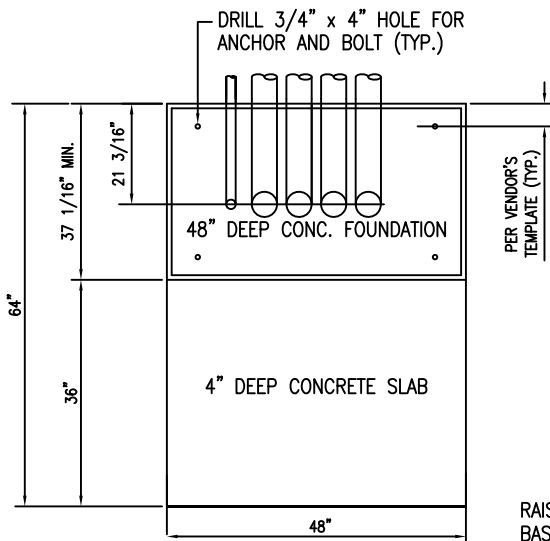

FOUNDATION PLAN

#6 (MIN.) COPPER INSULATED GROUND WIRE FROM DISCONNECT TO CONTROLLER CABINET WITH 48" OF SLACK ABOVE FOUNDATION

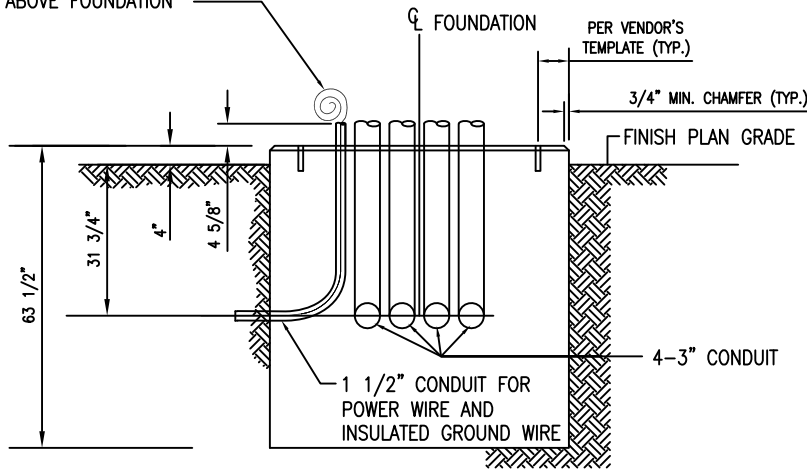

FOUNDATION ELEVATION VIEW

BASE MOUNTED TRAFFIC SIGNAL CONTROLLER CABINET

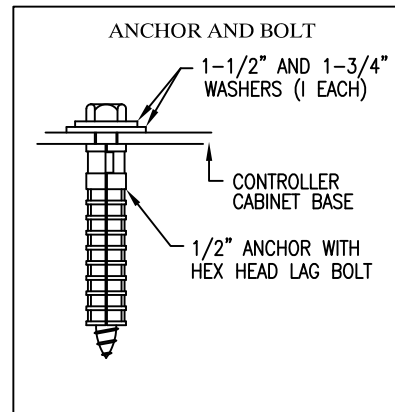
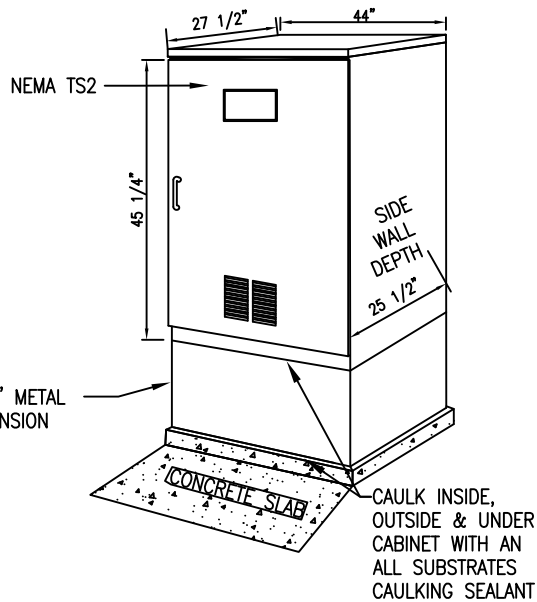

NOTES:

NO SCALE.

DIRECTION OF CONDUIT EXITING THE FOUNDATION IS NOT NECESSARILY AS SHOWN. CONSTRUCT CONDUIT TO EXIT THE FOUNDATION AS SHOWN ON THE PLAN OR AS DIRECTED BY THE ENGINEER.

ALL GROUNDS SHALL PROVIDE LESS THAN 10 OHM RESISTANCE TO GROUND.

ALL CONDUIT SHOWN SHALL BE SCHEDULE 80 PVC (POLYVINYL CHLORIDE) UNLESS OTHERWISE SPECIFIED OR DIRECTED BY THE ENGINEER.

CONDUIT SHALL HAVE 90° SWEEP ON 36" RADIUS.

CONDUIT OPENINGS IN THE CABINET SHALL BE BLOCKED BY TIGHTLY PACKING STEEL WOOL A MINIMUM OF 6 INCHES DEEP FOR RODENT CONTROL.



555 N Zeeb Rd  
Ann Arbor, MI 48103  
734-761-1500

	Initials	Date
Created by	JDM	09/2003
Revised by	RLH	10/10/2023
Approved by	JPY	10/10/2023

BASE MOUNTED TRAFFIC SIGNAL CONTROLLER FOUNDATION & CABINET

SIDE OF STEEL POLE CONTROLLER CABINET

NO SCALE

NOTES:

TRAFFIC SIGNAL CABLES SHALL BE FISHED THROUGH INSIDE OF STEEL STRAIN POLE FROM CABINET TO SIGNAL SPAN WIRE OR MAST ARM OR TO CONDUIT IN POLE FOUNDATION.

DRILL HOLES IN BACK OF CABINET TO MATCH CABINET MOUNTING BRACKET WELDED TO POLE

2 - 5/16" STAINLESS STEEL BOLT & WASHER

GROUND WIRE NO. 6 AWG MIN., COPPER  
CABINET GROUNDING TERMINAL BUS

2 - 5/16" STAINLESS STEEL BOLT & WASHER

LOCK NUT  
4" GAVANIZED STEEL CONDUIT  
4" ENTRANCE LB., GALVANIZED STEEL  
4" GALVANIZED STEEL HALF COUPLING WELDED TO POLE

#6 (MIN.) COPPER INSULATED GROUND WIRE FROM DISCONNECT TO BUSBAR IN CONTROLLLER CABINET

4" GALVANIZED STEEL CONDUIT

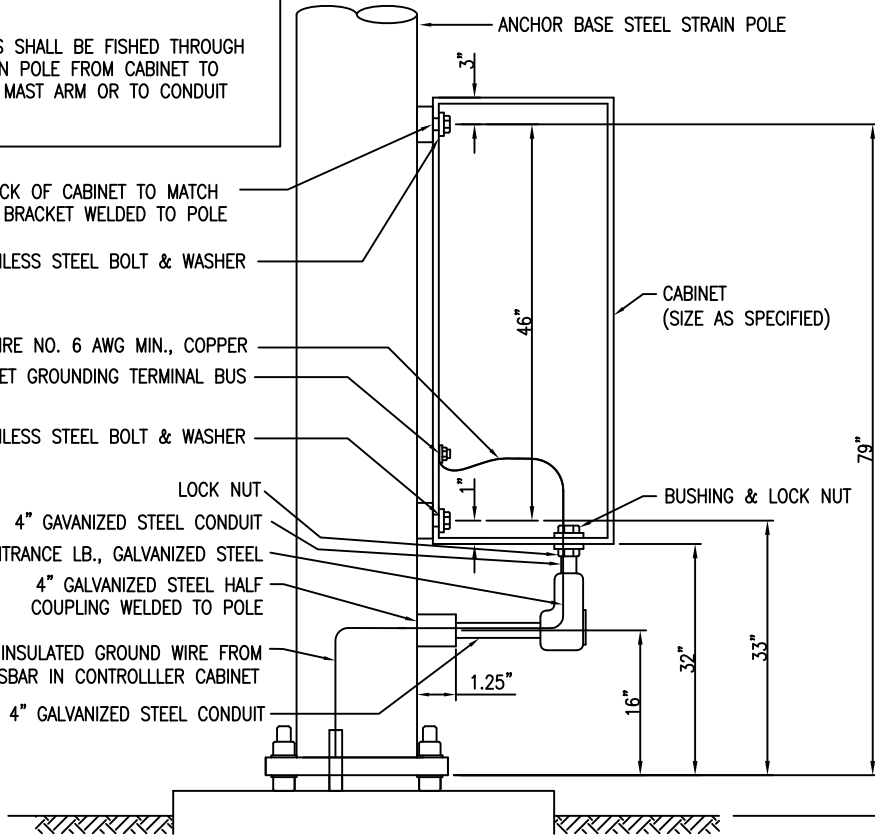

SIDE OF POLE SIGNAL DETECTOR/VIDEO CABINET (DETAIL)

NO SCALE

NOTES:

TRAFFIC SIGNAL CABLES SHALL BE FISHED THROUGH INSIDE OF STEEL STRAIN POLE FROM CABINET TO SIGNAL SPAN WIRE OR MAST ARM OR TO CONDUIT IN POLE FOUNDATION.

DRILL HOLES IN BACK OF CABINET TO MATCH CABINET MOUNTING BRACKET WELDED TO POLE

2 - 5/16" STAINLESS STEEL BOLT & WASHER

GROUND WIRE NO. 6 AWG MIN., COPPER  
CABINET GROUNDING TERMINAL BUS

2 - 5/16" STAINLESS STEEL BOLT & WASHER

LOCK NUT  
4" GAVANIZED STEEL CONDUIT  
4" ENTRANCE LB., GALVANIZED STEEL  
4" GALVANIZED STEEL HALF COUPLING WELDED TO POLE

#6 (MIN.) COPPER INSULATED GROUND WIRE FROM BUSBAR IN CONTROLLLER CABINET TO GROUND ROD

4" GALVANIZED STEEL CONDUIT

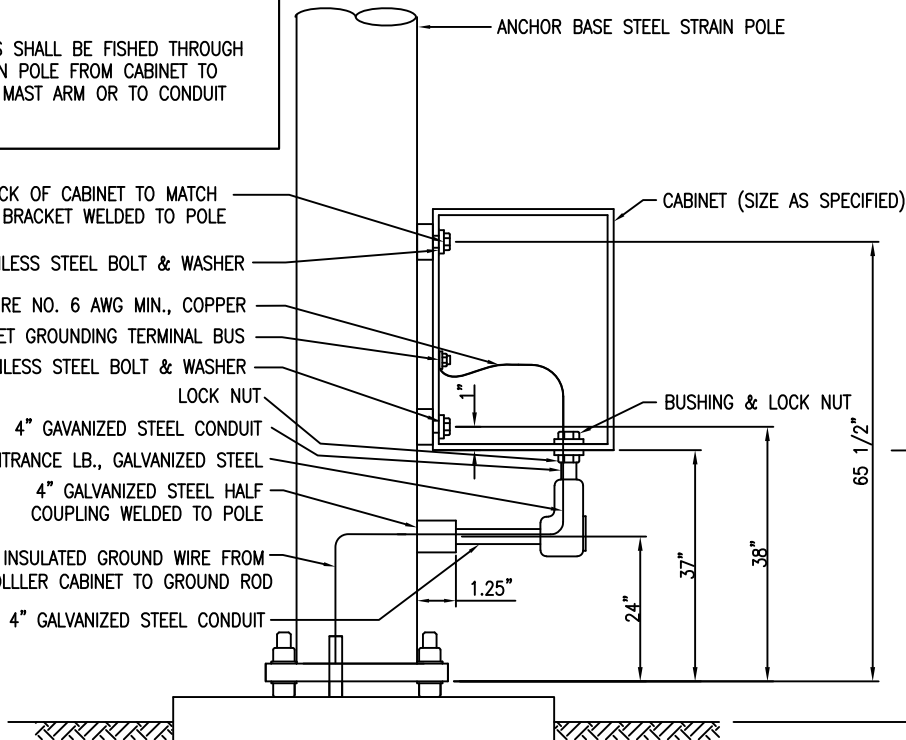

555 N Zeeb Rd  
Ann Arbor, MI 48103  
734-761-1500

	Initials	Date
Created by	JDM	09/2003
Revised by	RLH	10/10/2023
Approved by	JPY	10/10/2023

SIDE OF POLE SIGNAL/DIGITAL LOOP  
DETECTOR/CONTROLLER CABINET

WASH-10

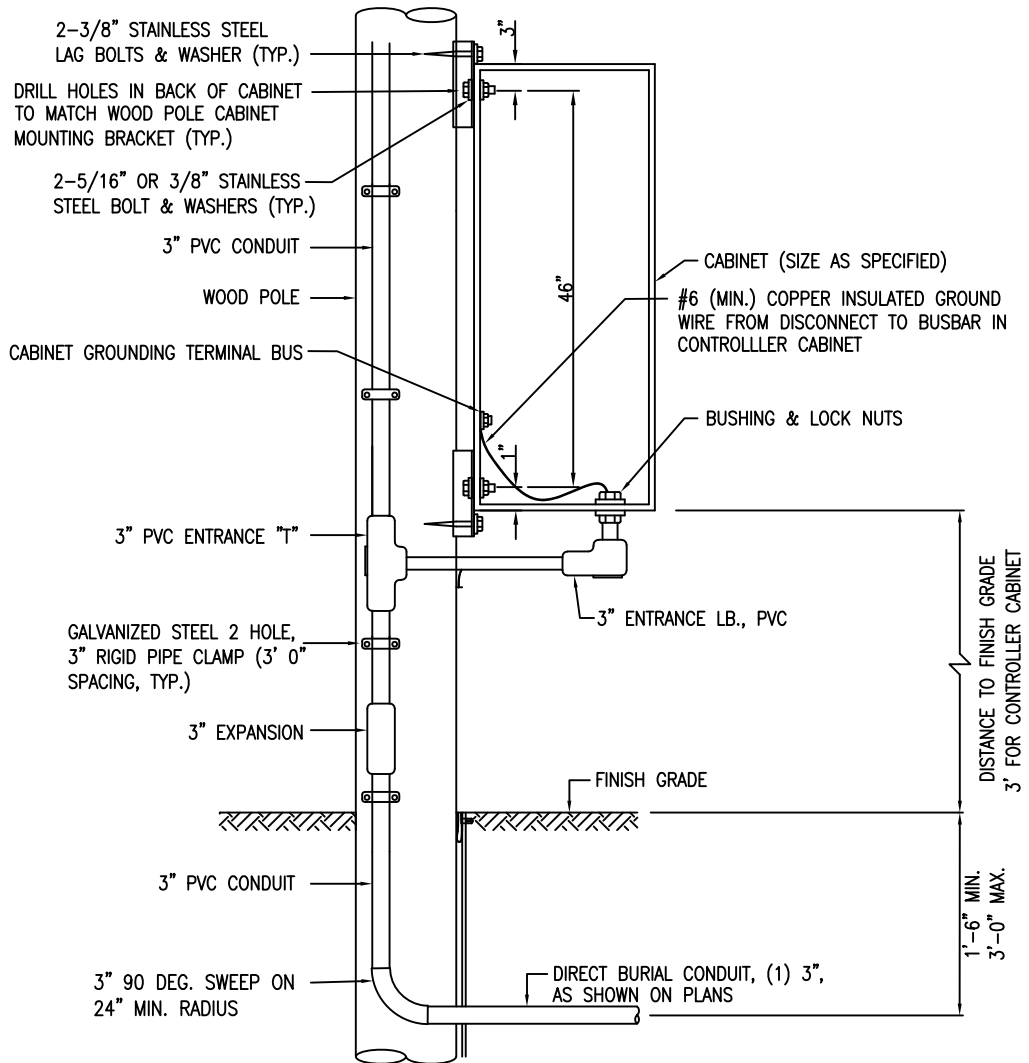

NOTES:  
 NO SCALE

USE CONDUIT SIZE SPECIFIED (MIN.) UNLESS CURRENT NATIONAL ELECTRIC CODE INDICATES A LARGER SIZE IS REQUIRED.

ALL CONDUIT SHALL BE SCHEDULE 80 PVC (POLYVINYL CHLORIDE) UNLESS OTHERWISE SPECIFIED OR DIRECTED BY THE ENGINEER.

INSTALL No. 6 COPPER INSULATED GROUND WIRE FROM DISCONNECT TO CABINET GROUNDING TERMINAL BUS.



555 N Zeeb Rd  
 Ann Arbor, MI 48103  
 734-761-1500

	Initials	Date
Created by	JDM	09/2003
Revised by	RLH	10/10/2023
Approved by	JPY	10/10/2023

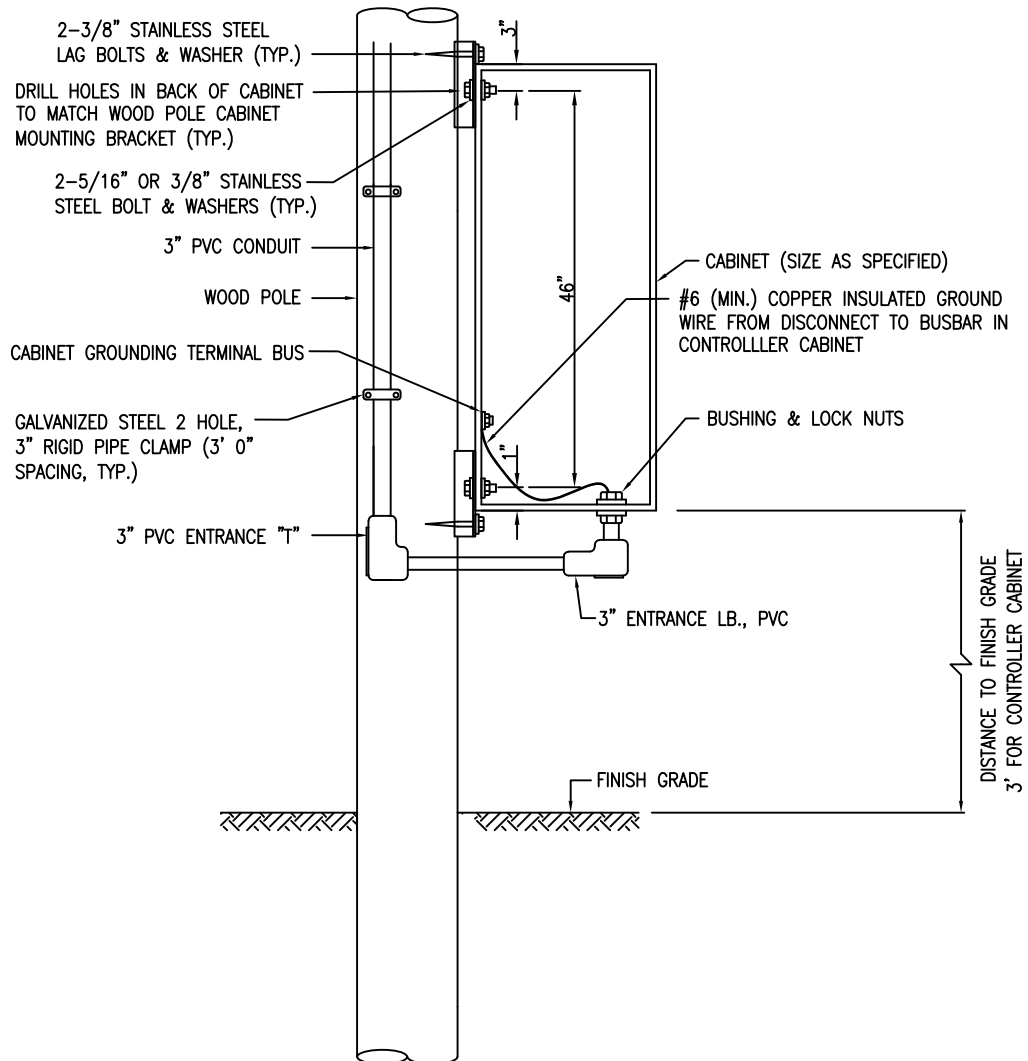

NOTES:  
 NO SCALE  
 USE CONDUIT SIZE SPECIFIED (MIN.) UNLESS CURRENT NATIONAL ELECTRIC CODE INDICATES A LARGER SIZE IS REQUIRED.  
 ALL CONDUIT SHALL BE SCHEDULE 80 PVC (POLYVINYL CHLORIDE) UNLESS OTHERWISE SPECIFIED OR DIRECTED BY THE ENGINEER.  
 INSTALL No. 6 COPPER INSULATED GROUND WIRE FROM DISCONNECT TO CABINET GROUNDING TERMINAL BUS.



555 N Zeeb Rd  
 Ann Arbor, MI 48103  
 734-761-1500

	Initials	Date
Created by	JDM	09/2003
Revised by	RLH	10/10/2023
Approved by	JPY	10/10/2023

**SIDE OF WOOD POLE SIGNAL CONTROLLER CABINET (NO GROUND CONDUIT)**

WASH-10

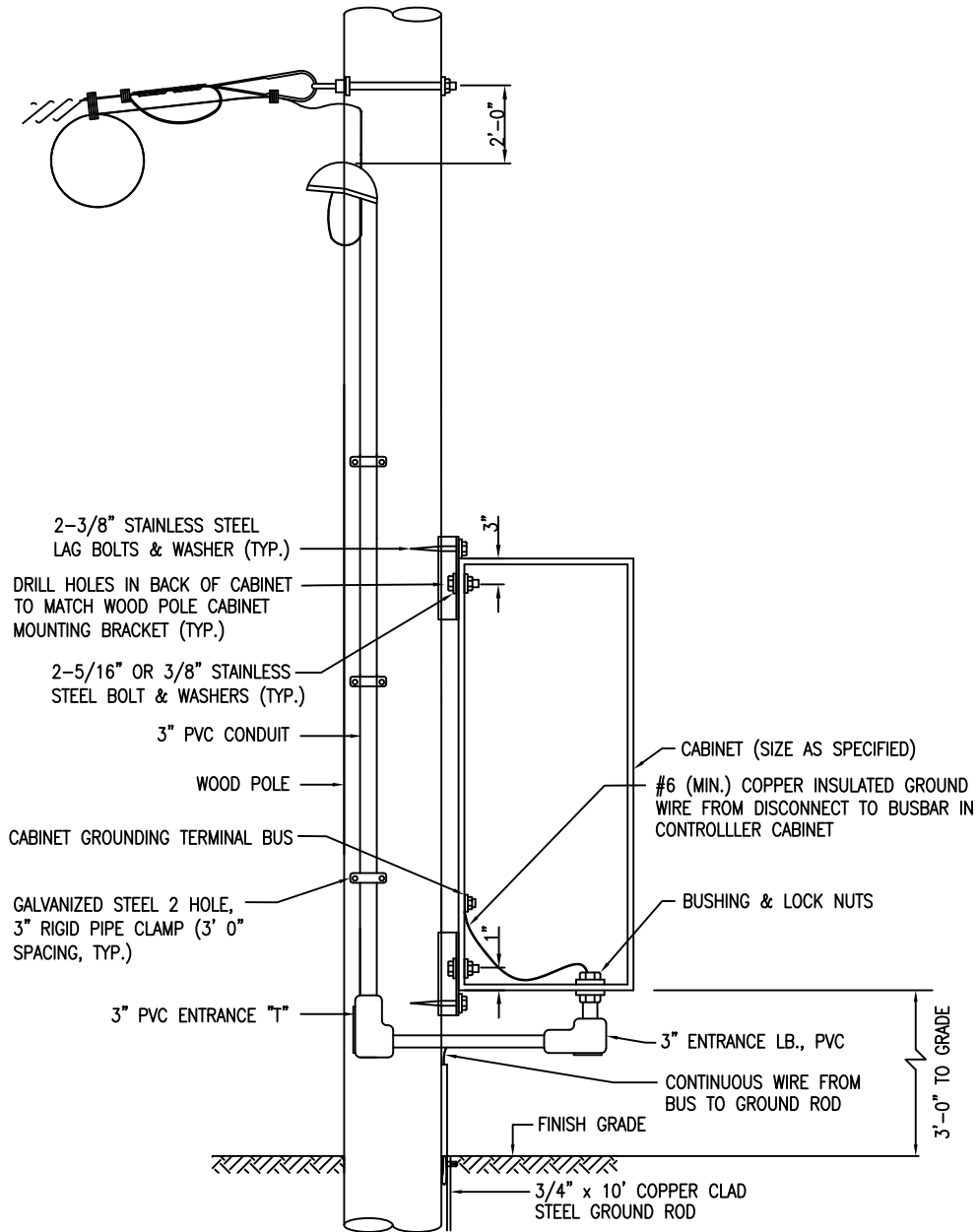

NOTES:  
NO SCALE

USE CONDUIT SIZE SPECIFIED (MIN.) UNLESS CURRENT NATIONAL ELECTRIC CODE INDICATES A LARGER SIZE IS REQUIRED.

ALL CONDUIT SHALL BE SCHEDULE 80 PVC (POLYVINYL CHLORIDE) UNLESS OTHERWISE SPECIFIED OR DIRECTED BY THE ENGINEER.

INSTALL 3/4" x 10' COPPER CLAD GROUND ROD, AS REQUIRED, TO PROVIDE LESS THAN 10 OHM RESISTANCE TO GROUND.  
INSTALL No. 6 COPPER GROUND WIRE FROM GROUND ROD TO CABINET GROUNDING TERMINAL BUS.



555 N Zeeb Rd  
Ann Arbor, MI 48103  
734-761-1500

	Initials	Date
Created by	JDM	09/2003
Revised by	RLH	10/11/2023
Approved by	JPY	10/11/2023

TEMPORARY TRAFFIC SIGNAL  
CONTROLLER CABINET

WASH-11

**TOP MOUNTING BRACKET**

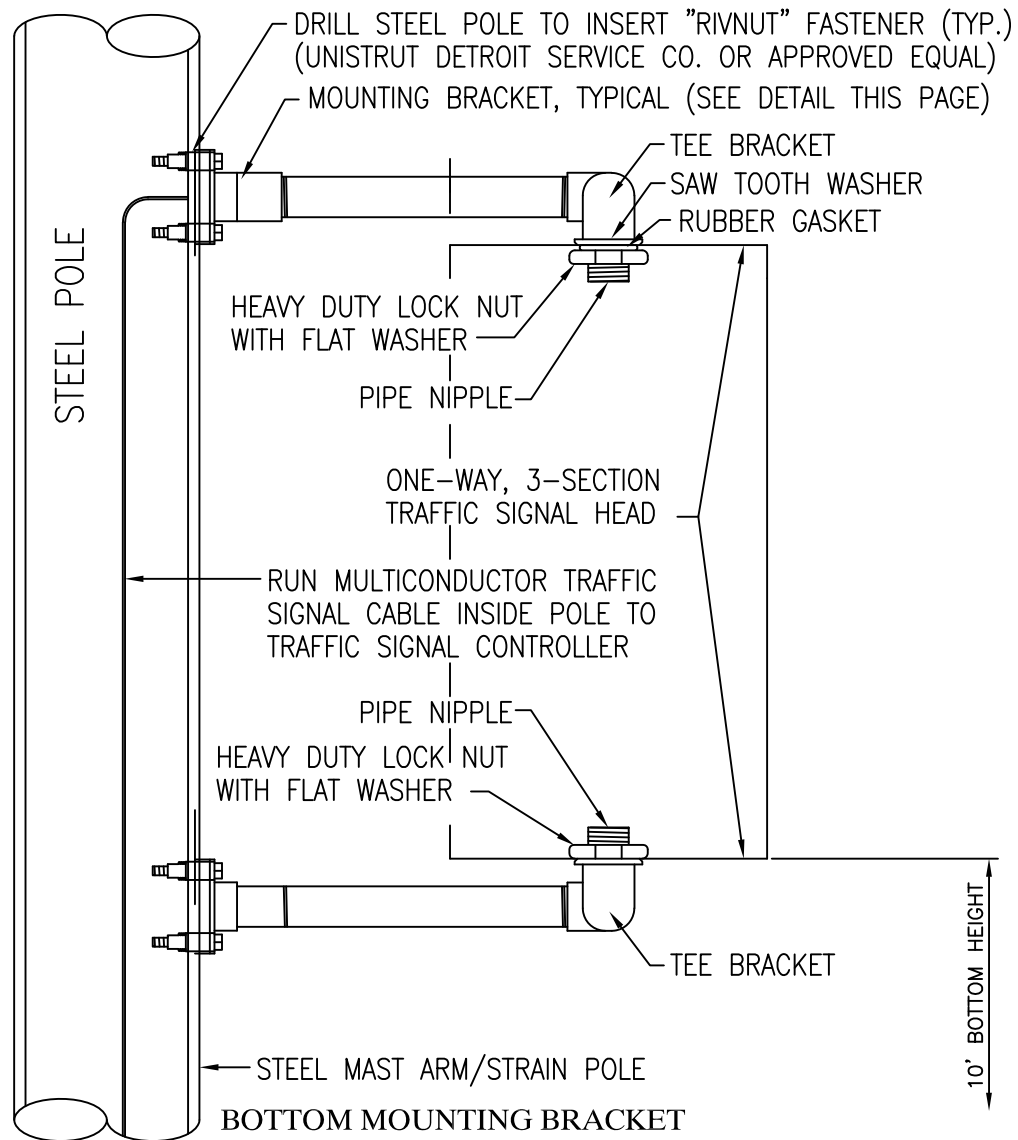

**MOUNTING BRACKET DETAIL**

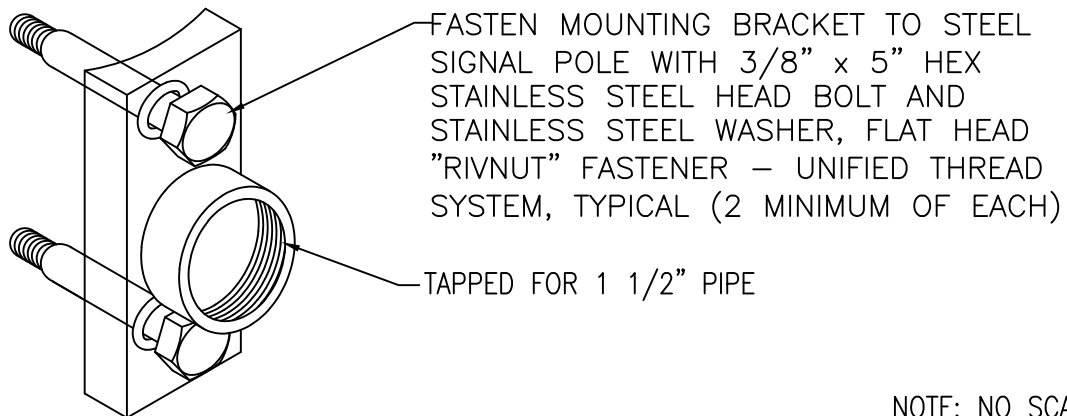

NOTE: NO SCALE



555 N Zeeb Rd  
Ann Arbor, MI 48103  
734-761-1500

	Initials	Date
Created by	JDM	09/2003
Revised by	RLH	10/11/2023
Approved by	JPY	10/11/2023

**BRACKET ARM MOUNTED VEHICULAR TRAFFIC SIGNAL STEEL POLE**

WASH-12

TOP MOUNTING BRACKET

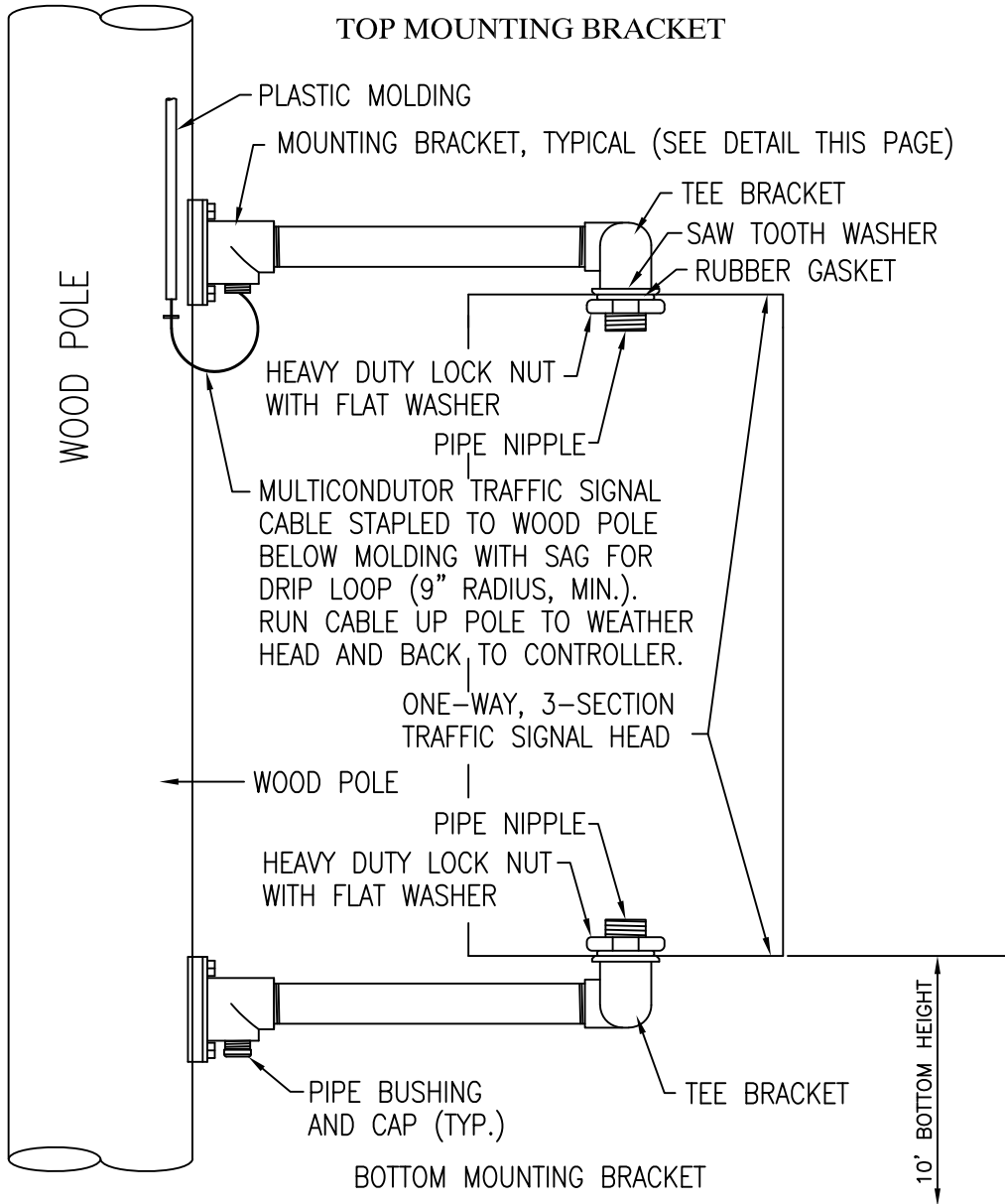

MOUNTING BRACKET DETAIL

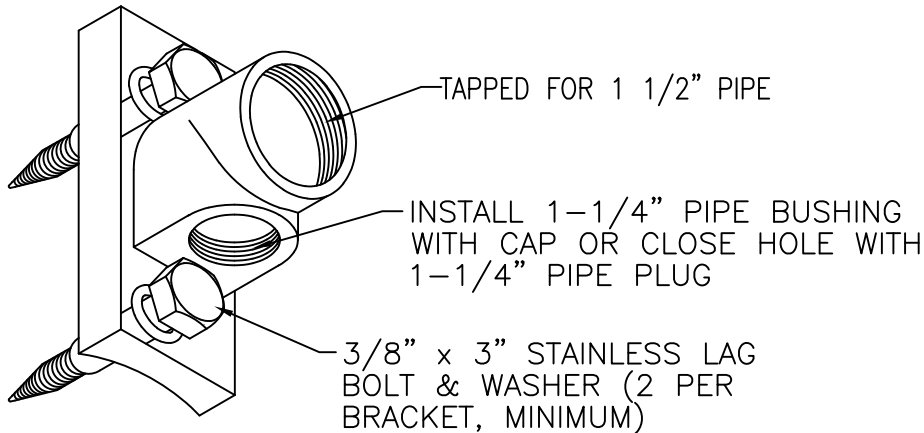

NOTE: NO SCALE



555 N Zeeb Rd  
Ann Arbor, MI 48103  
734-761-1500

	Initials	Date
Created by	JDM	09/2003
Revised by	RLH	10/11/2023
Approved by	JPY	10/11/2023

BRACKET ARM MOUNTED VEHICULAR  
TRAFFIC SIGNAL WOOD POLE

WASH-12

Page 2 of 4

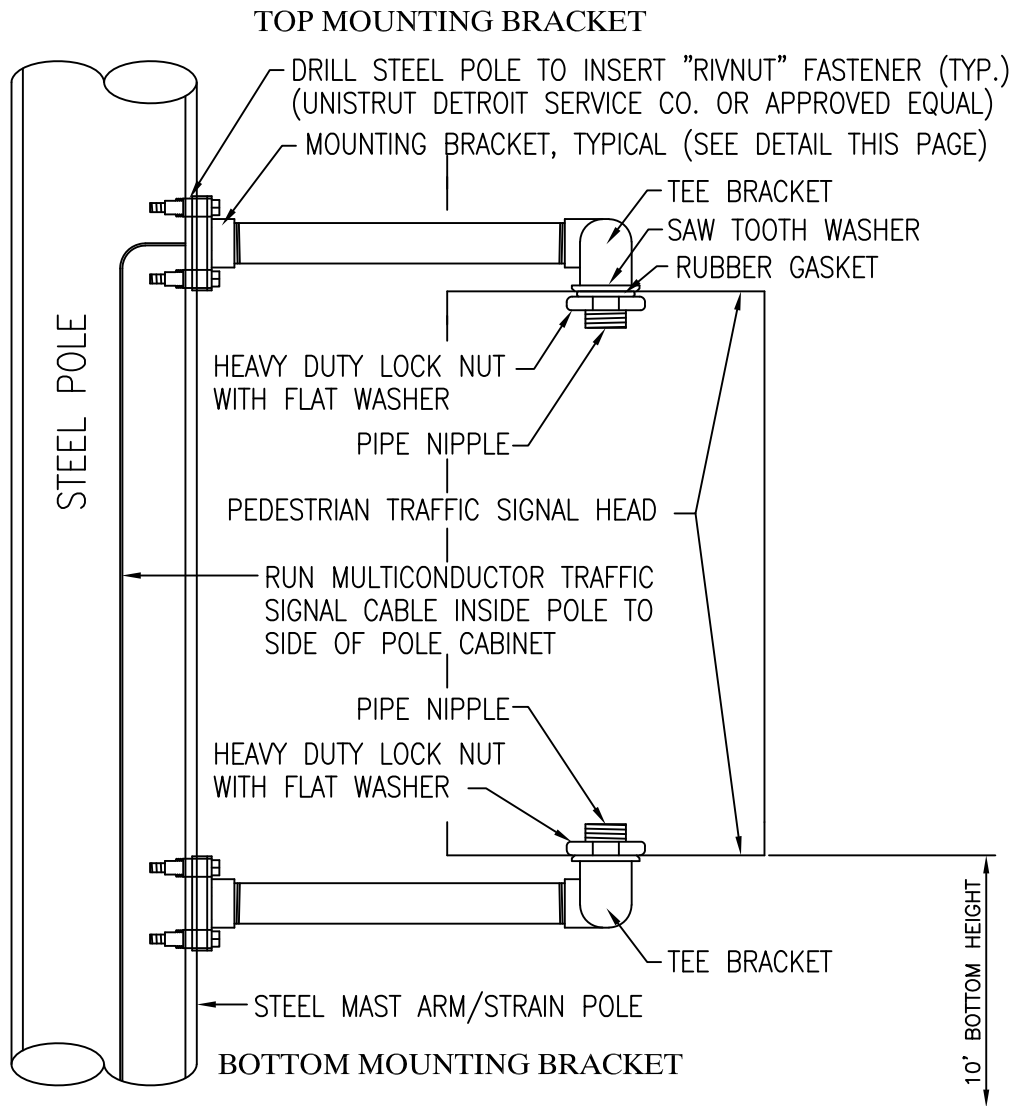

**MOUNTING BRACKET DETAIL**

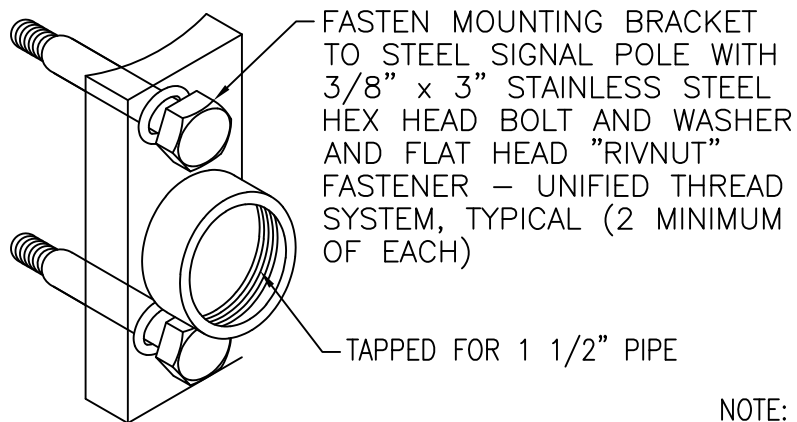

NOTE: NO SCALE



555 N Zeeb Rd  
Ann Arbor, MI 48103  
734-761-1500

	Initials	Date
Created by	JDM	09/2003
Revised by	RLH	10/11/2023
Approved by	JPY	10/11/2023

**BRACKET ARM MOUNTED PEDESTRIAN TRAFFIC SIGNAL STEEL POLE**

WASH-12



**TOP MOUNTING BRACKET**

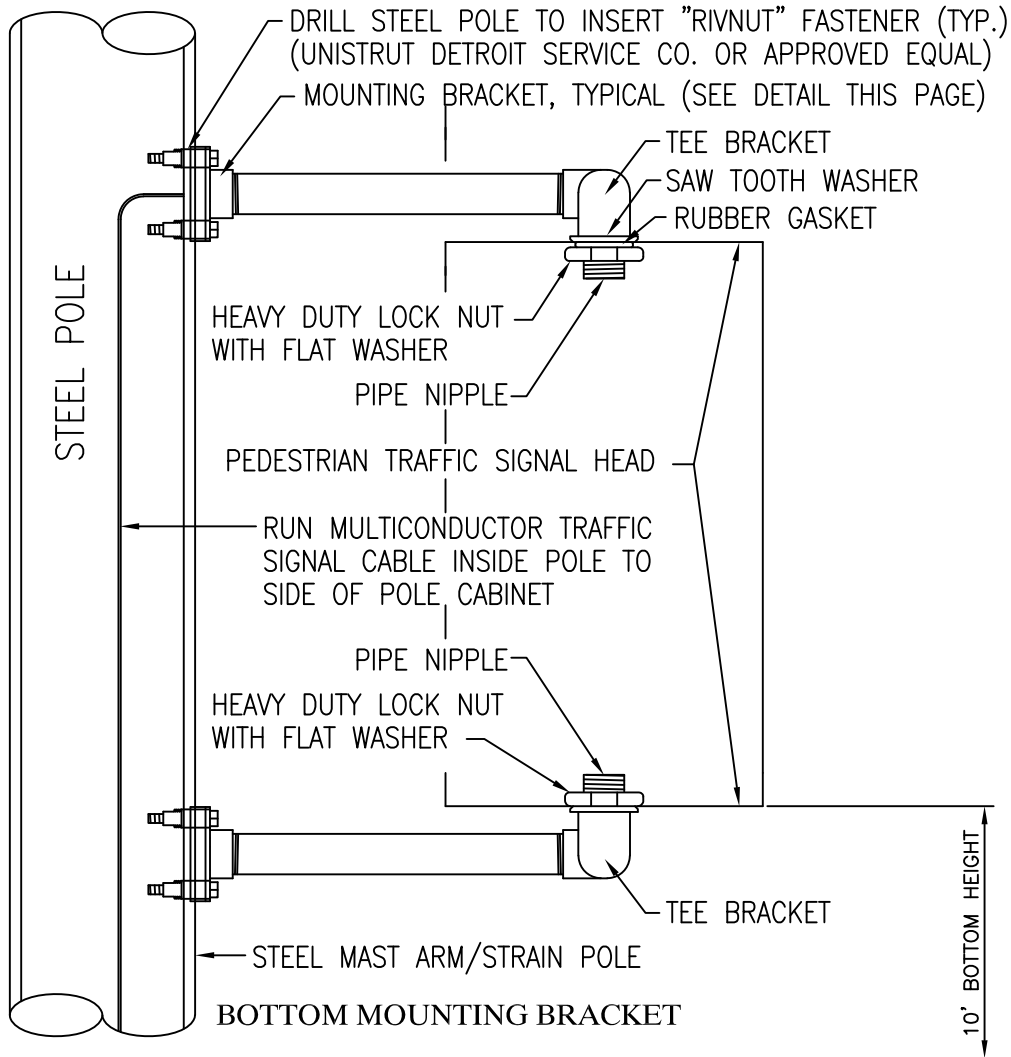

**MOUNTING BRACKET DETAIL**

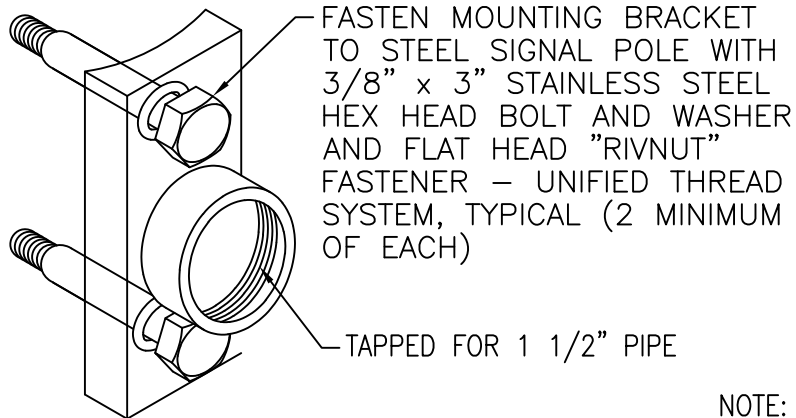

NOTE: NO SCALE



555 N Zeeb Rd  
Ann Arbor, MI 48103  
734-761-1500

	Initials	Date
Created by	JDM	09/2003
Revised by	RLH	10/11/2023
Approved by	JPY	10/11/2023

**BRACKET ARM MOUNTED PEDESTRIAN TRAFFIC SIGNAL WOOD POLE**

WASH-12

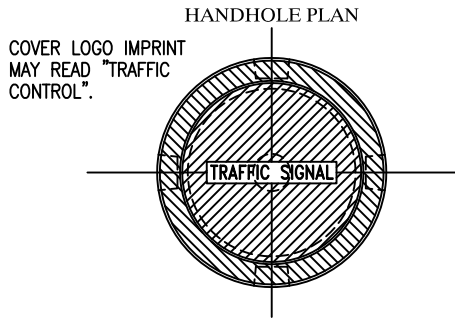

FRAME AND BOLT DOWN COVER SHALL BE EAST JORDAN IRON WORKS, #2860 PT (FRAME TYPE 1) OR AN APPROVED EQUAL.

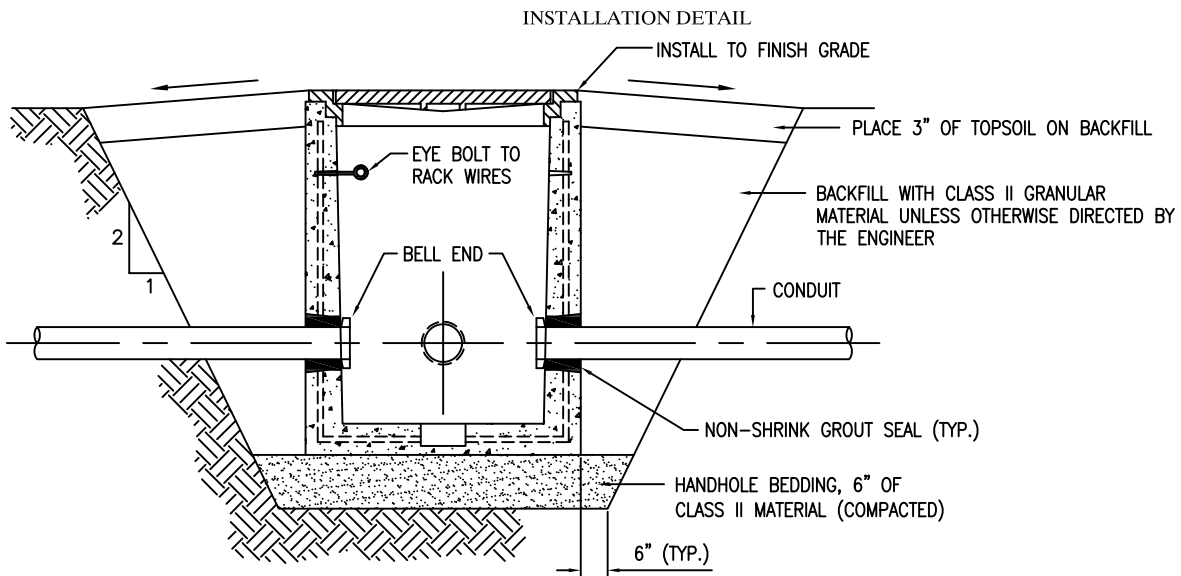
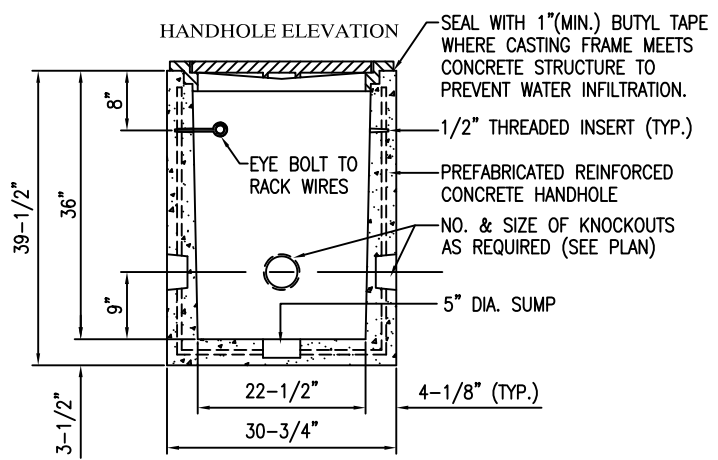

NOTES:  
NO SCALE.

THE CONDUIT SHALL ONLY PROTRUDE THE REQUIRED AMOUNT OF DISTANCE TO INSTALL THE BELL END.

THE MATERIAL AND WORKMANSHIP SHALL BE IN ACCORDANCE WITH CURRENT M.D.O.T. STANDARD SPECIFICATIONS.

THE INNER SURFACE OF THE HANDHOLE SHALL BE SMOOTH.

HEAVY DUTY COVERS SHALL BE CASTINGS WHICH MEET THE REQUIREMENTS OF THE CURRENT SPECIFICATIONS FOR GRAY IRON CASTINGS ASTM DESIGNATION A48 AND SHALL HAVE A MINIMUM STRENGTH AS PROVIDED FOR CLASS No. 30 GRAY IRON CASTINGS. ALL CASTINGS SHALL BE CLEANED BY SAND BLASTING.

THE SEATING FACE OF THE COVER AND THE SEAT FOR THE SAME ON THE FRAME, IF REQUIRED, SHALL BE GROUND OR MACHINED SO THAT THE COVER SHALL HAVE AN EVEN BEARING ON THE SEAT TO PREVENT ROCKING OR TILTING.

THE CASTINGS SHALL BE FREE OF POURING FAULTS, BLOW HOLES, CRACKS, AND OTHER IMPERFECTIONS. THEY SHALL BE SOUND, TRUE TO FORM AND THICKNESS, CLEAN AND NEATLY FINISHED, AND SHALL BE COATED WITH TAR PITCH VARNISH.

NUMBER AND SIZE OF CONDUIT OPENING(S) SHALL BE PROVIDED AS REQUIRED, SEE PLANS.

CONDUIT ARRANGEMENT SHOWN ON PLANS MAY BE MODIFIED WITH APPROVAL BY THE ENGINEER.

PLUG ALL UNUSED ENTRANCE HOLES AND SEAL AROUND HOLES ENTERED.

SIZE, QUANTITY, AND TYPE OF PVC CONDUIT SHALL BE AS SHOWN ON THE PLANS. METHOD OF PVC CONDUIT INSTALLATION SHALL BE AS SHOWN ON THE PLANS, AS SPECIFIED IN THE PROPOSAL, OR AS DIRECTED BY THE ENGINEER.

THE NON-SHRINK GROUT SHALL BE PLACED INSIDE AND OUTSIDE OF THE CONCRETE HANDHOLE.



555 N Zeeb Rd  
Ann Arbor, MI 48103  
734-761-1500

	Initials	Date
Created by	JDM	09/2003
Revised by	RLH	10/11/2023
Approved by	JPY	10/11/2023

## TRAFFIC SIGNAL HANDHOLE

WASH-13

Page 1 of 1

### CONDUIT TRENCH NOT UNDER ROADWAY

NO SCALE

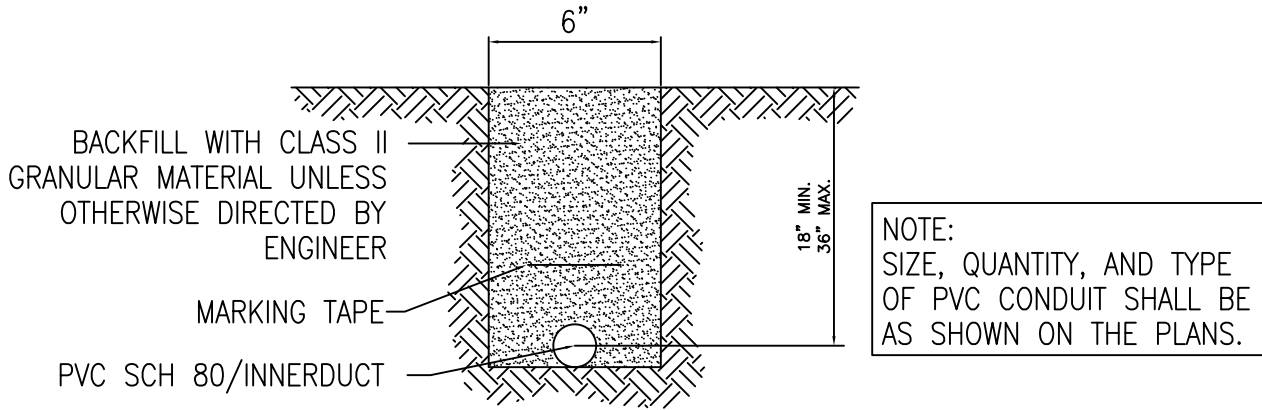

### CONDUIT TRENCH IN THE INFLUENCE OF ROADWAY

NO SCALE

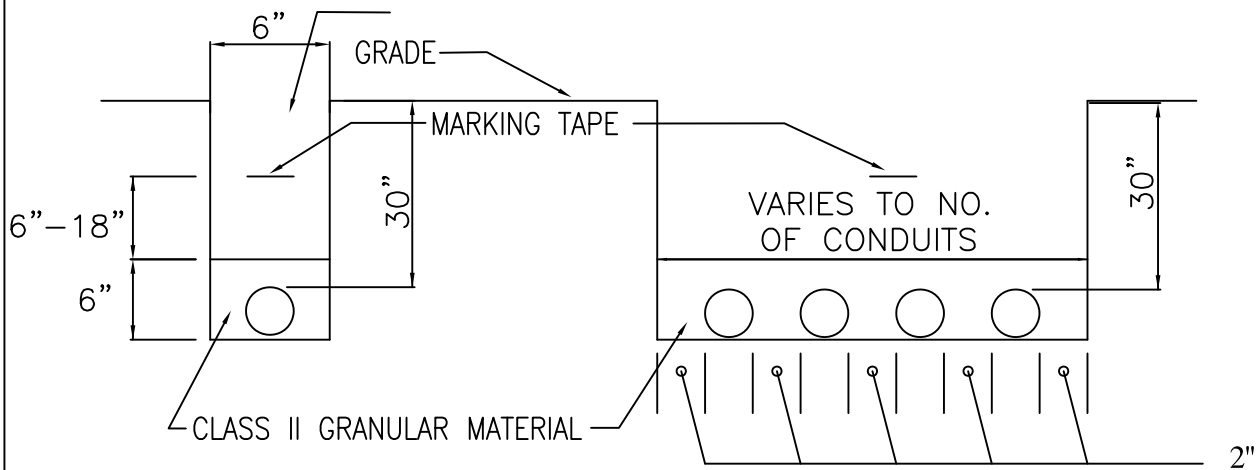

### CONDUIT/INNERDUCT BORES UNDER ROADWAY

NO SCALE

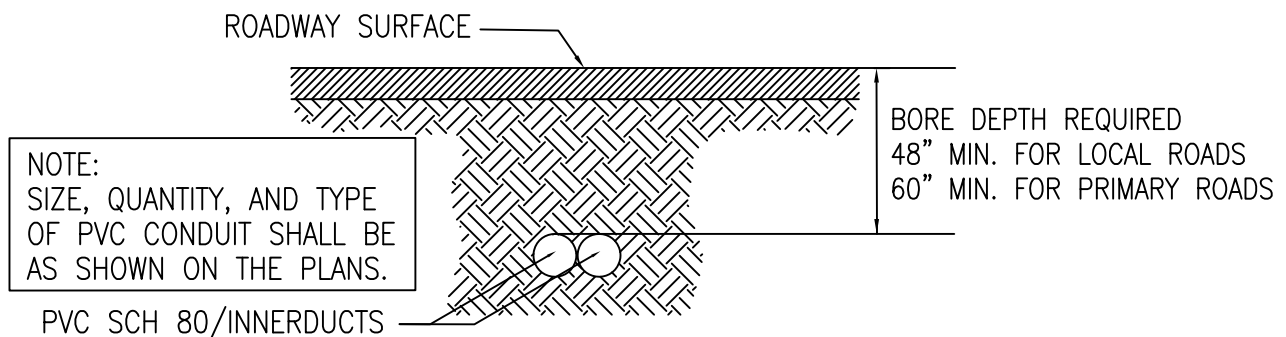

NOTE:  
MARKING TAPE SHALL HAVE PROPER LOGO AS SUPPLIED BY THE ENGINEER AND INSTALLED BY THE CONTRACTOR.



555 N Zeeb Rd  
Ann Arbor, MI 48103  
734-761-1500

	Initials	Date
Created by	JDM	09/2003
Revised by	RLH	10/12/2023
Approved by	JPY	10/12/2023

CONDUIT TRENCH  
DIRECT BURIAL  
DIRECTIONAL / JACK BORES

WASH-14

Page 1 of 1



555 N Zeeb Rd  
Ann Arbor, MI 48103  
734-761-1500

	Initials	Date
Created by	JDM	09/2003
Revised by	RLH	10/12/2023
Approved by	JPY	10/12/2023

### TRAFFIC SIGNAL LOOP (SAWED IN)

WASH-15

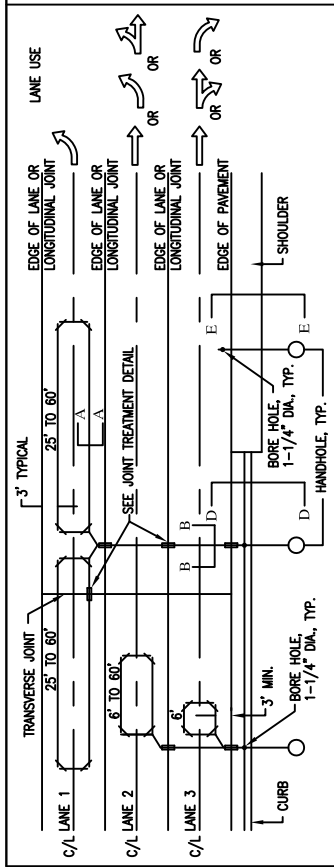

TYPICAL SAWCUT SLOT CROSS SECTIONS

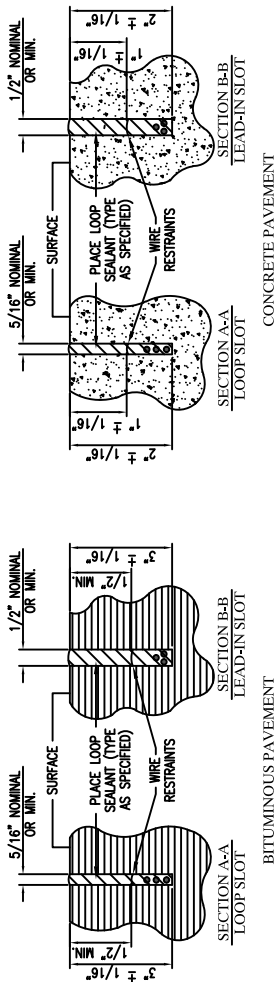

CONCRETE PAVEMENT

BITUMINOUS PAVEMENT

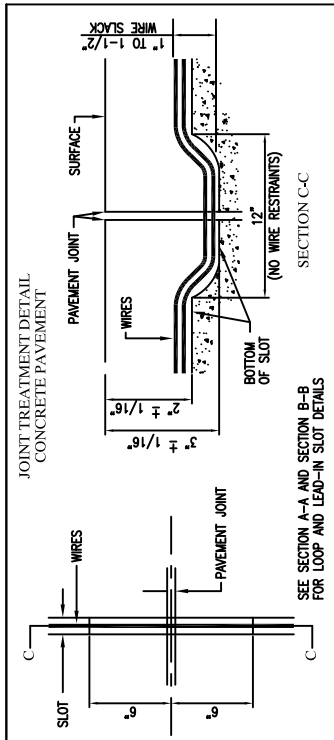

SEE SECTION A-A AND SECTION B-B FOR LOOP AND LEAD-IN SLOT DETAILS

NOTES:

1. TURNS OF WIRE PER LOOP SHALL BE AS SPECIFIED IN THE PROJECT SPECIAL PROVISIONS. WIRES SHALL NOT BE TWISTED IN THE LOOP SLOT.
2. LEAD-IN WIRES SHALL BE TWISTED IN THE LEAD-IN SLOTS.
3. LEAD-IN SLOT MAY BE ON EITHER NEAR OR FAR SIDE OF LOOP APPROACH AS DIRECTED BY THE ENGINEER.
4. LEAD-IN SAW CUT SHALL PROVIDE ACCESS TO NO MORE THAN TWO DETECTOR LOOPS.
5. SIZE, QUANTITY, AND TYPE OF RIGID CONDUIT SHALL BE AS SHOWN ON THE PLANS.
6. METHOD OF RIGID CONDUIT INSTALLATION SHALL BE AS SHOWN ON THE PLANS, AS SPECIFIED IN THE PROPOSAL, OR AS DIRECTED BY THE ENGINEER.

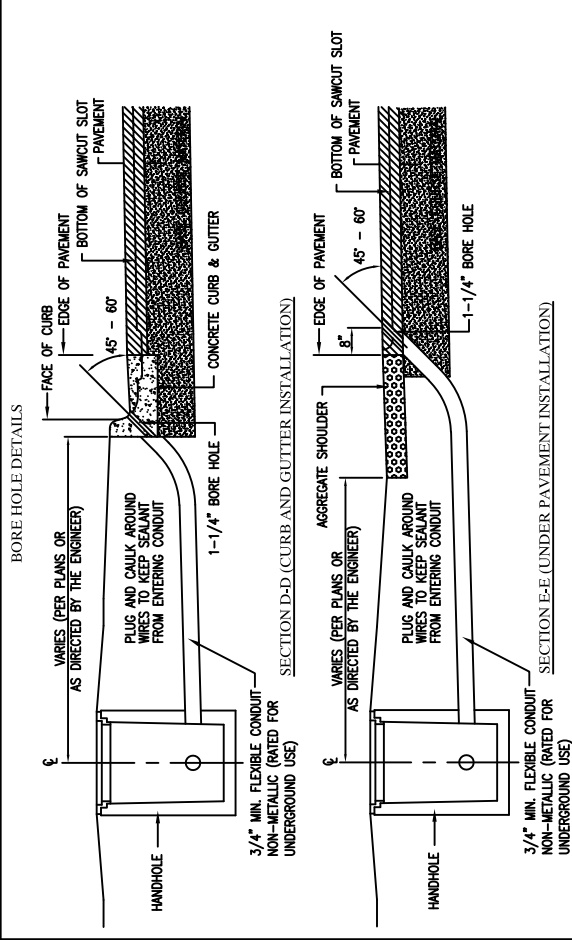

BORE HOLE DETAILS

SECTION D-D (CURB AND GUTTER INSTALLATION)

SECTION E-E (UNDER PAVEMENT INSTALLATION)

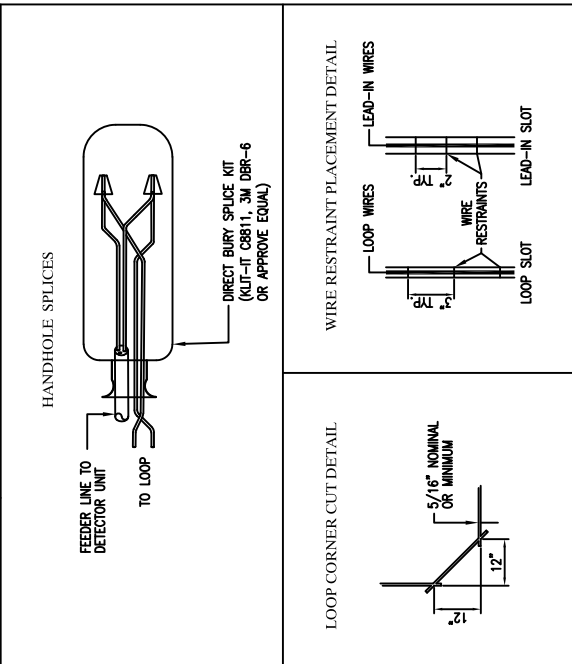

HANDHOLE SPLICES

LOOP CORNER CUT DETAIL

WIRE RESTRAINT PLACEMENT DETAIL

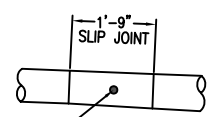
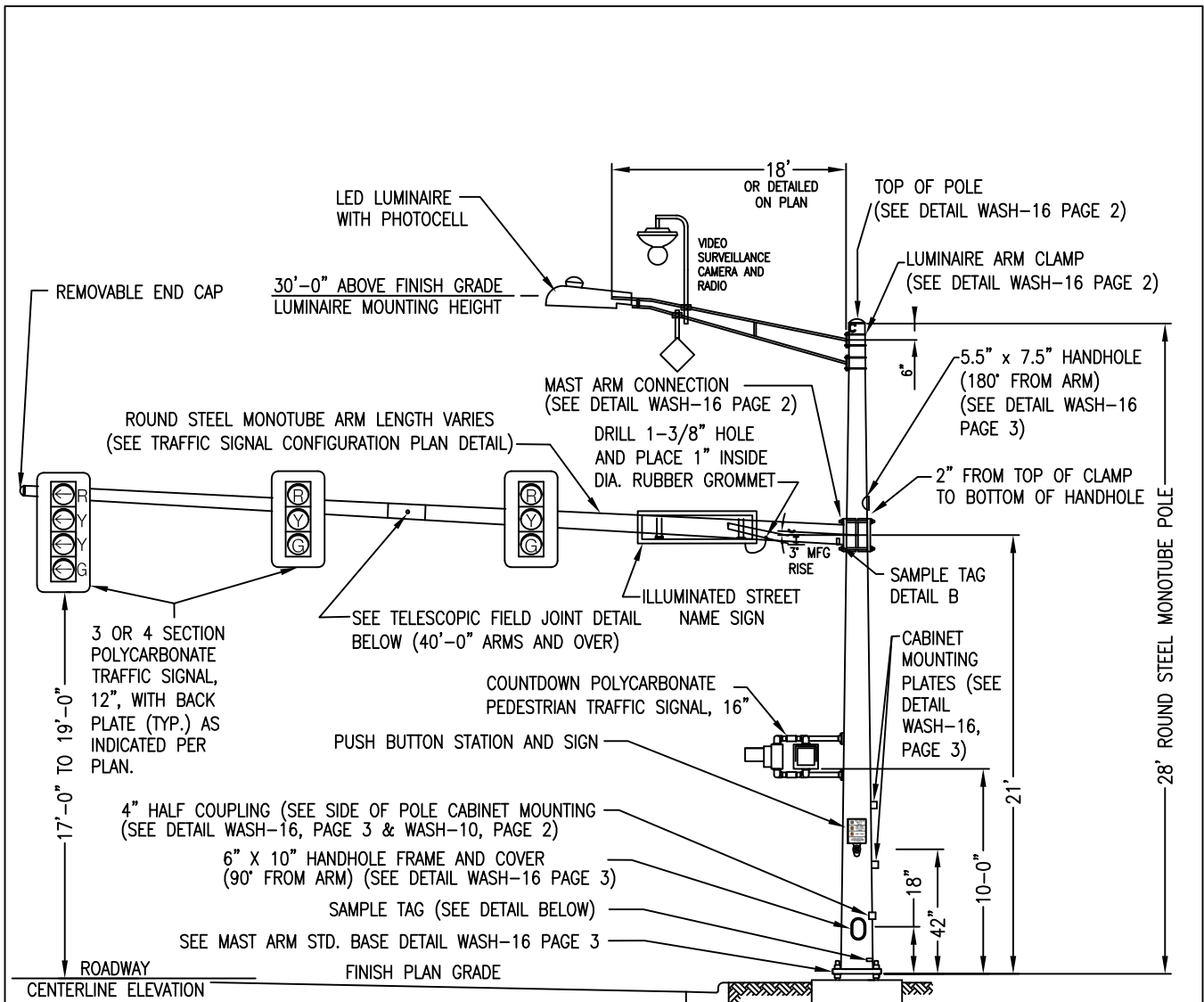

**TELESCOPIC FIELD JOINT DETAIL**  
 5/8" DIA. GALV. STUD WITH (2) "ANCO" LOCK NUTS.  
 3/4" DIA. HOLE FACTORY DRILLED IN OUTBOARD TUBE.  
 FIELD DRILL INBOARD TUBE TO ASSURE SNUG FIT.  
 (ORIENTATION SHALL BE HORIZONTAL)

**NOTES:**  
 NO SCALE.  
 TRAFFIC SIGNALS SHALL BE MOUNTED TO THE MAST ARM. TRAFFIC SIGNAL FACES SHALL BE DIRECTED PARALLEL TO THE CENTERLINE OF THE ROAD THAT THEY CONTROL, MOUNTED IN THE CENTER OF THE LANE THEY CONTROL ON MULTI LANE ROADWAYS, AND WITH RED INDICATIONS AS SHOWN ABOVE OR AS DIRECTED BY THE ENGINEER.

FOR FOUNDATION  
 SEE MDOT MAST ARM  
 STANDARD FOUNDATIONS (SIG-040-A)

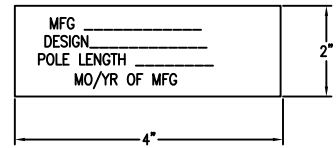

**SAMPLE POLE & ARM TAGS DETAIL**  
 TO BE ATTACHED TO POLE OR ARM 4" FROM  
 BASE OF TUBE (STAMPED IN 3/8" CHARACTORS)  
 ATTACHED TO POLE/ARM WITH (4) #8x3/8 SS  
 TYPE U DRIVE SCREWS EACH



555 N Zeeb Rd Ann Arbor, MI 48103 734-761-1500	Initials	Date
	Created by	JDM 09/2003
	Revised by	RLH 03/15/2024
	Approved by	JPY 03/15/2024

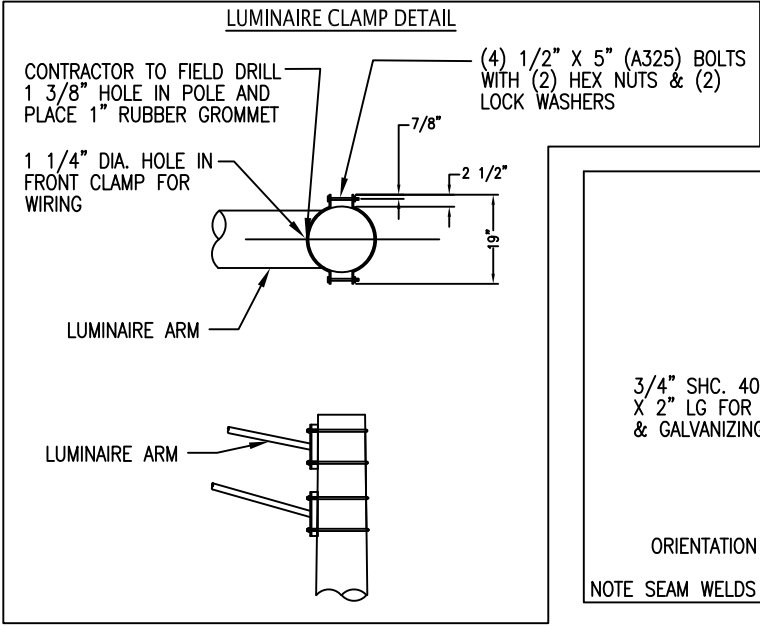

NOTE: NO SCALE.

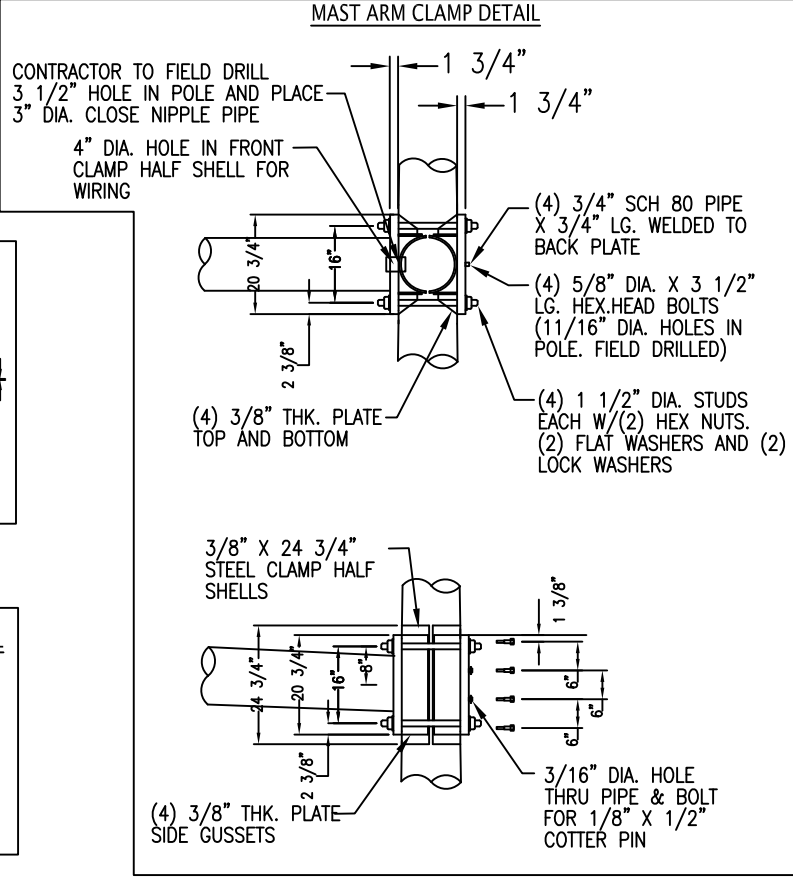
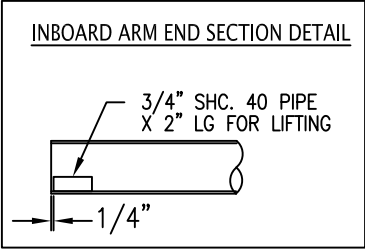
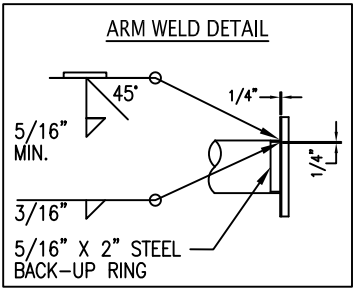
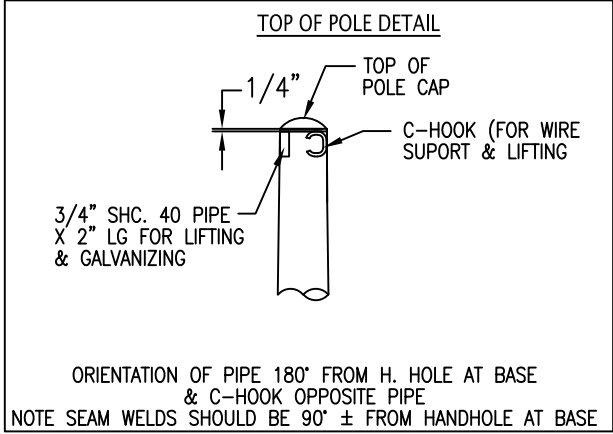

555 N Zeeb Rd  
Ann Arbor, MI 48103  
734-761-1500

	Initials	Date
Created by	JDM	09/2003
Revised by	RLH	10/12/2023
Approved by	JPY	10/12/2023

**MAST ARM BASE AND CLAMPS  
DETAIL**

CABINET MOUNTING BRACKET DETAIL

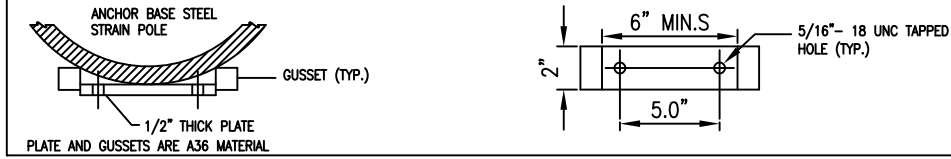

6" x 10" BAR HANDHOLE DETAIL

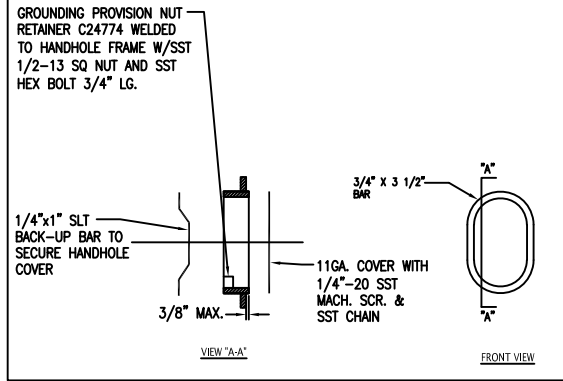

5.5" x 7.5" BAR HANDHOLE DETAIL

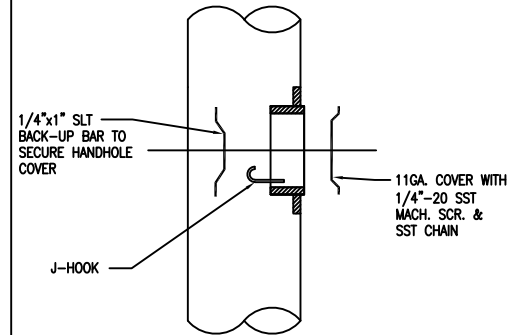

BASE DETAIL WITH DETECTOR CABINET

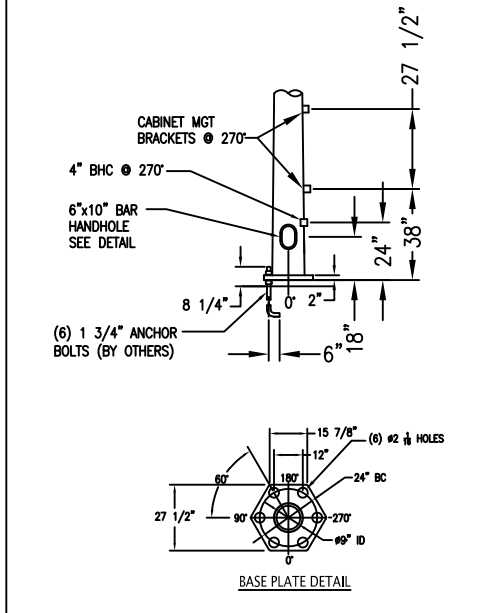

BASE DETAIL WITH CONTROLLER CABINET

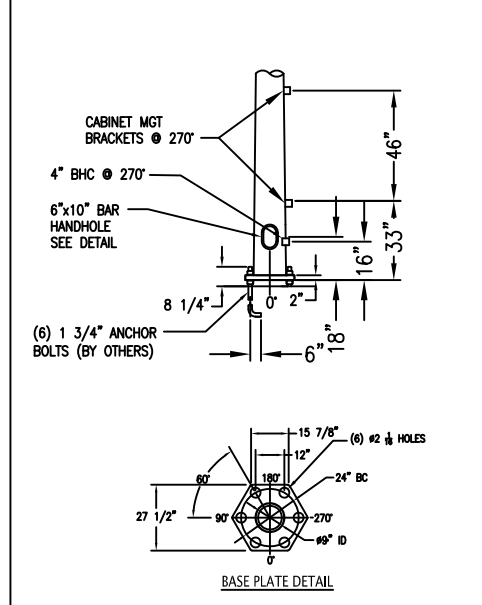

NOTE: NO SCALE.



555 N Zeeb Rd  
Ann Arbor, MI 48103  
734-761-1500

	Initials	Date
Created by	JDM	09/2003
Revised by	RLH	10/12/2023
Approved by	JPY	10/12/2023

**STEEL POLE HANDHOLE, CABINET BRACKET & POLE BASE**

WASH-16

### 4-SECTION TRAFFIC SIGNAL, 12"

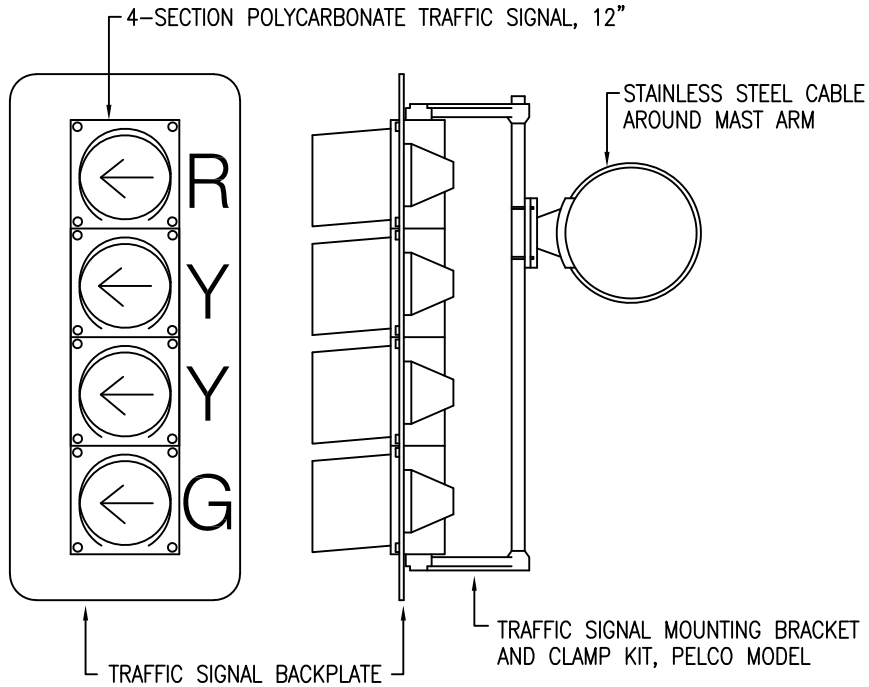

### 3-SECTION TRAFFIC SIGNAL, 12"

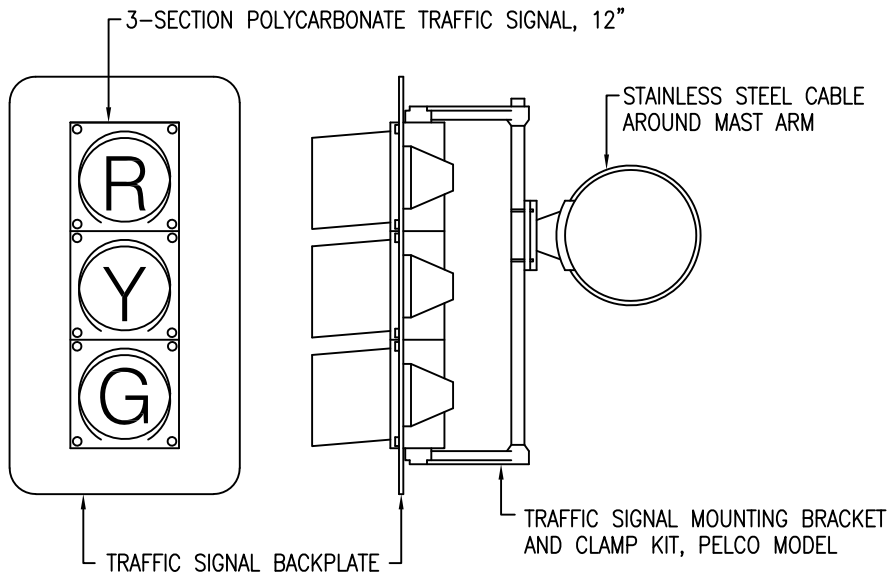

NOTES:  
NO SCALE.

FASTEN BACKPLATE TO THE SIGNAL HEAD WITH HEX HEAD SELF-TAPPING SCREWS AND WASHERS, USING THE PREFORMED HOLES ON THE BACK OF EACH SIGNAL SECTION (4 SCREWS PER SECTION).

SEE MANUFACTURER RECOMMENDATION FOR TORQUE SETTING ON CABLE MOUNT CLAMP KITS.



555 N Zeeb Rd  
Ann Arbor, MI 48103  
734-761-1500

	Initials	Date
Created by	JDM	09/2003
Revised by	RLH	10/12/2023
Approved by	JPY	10/12/2023

TRAFFIC SIGNAL  
INSTALLATION ON MAST ARM



5 SECTION TRAFFIC SIGNAL, 12"

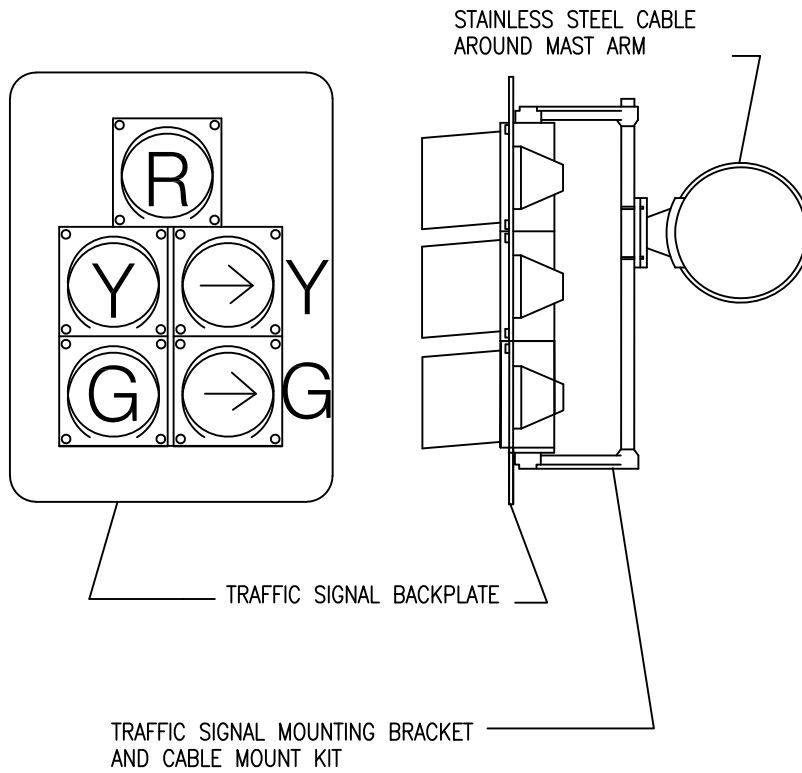

NOTES:  
 NO SCALE.

FASTEN BACKPLATE TO THE SIGNAL HEAD WITH HEX HEAD SELF-TAPPING SCREWS AND WASHERS, USING THE PREFORMED HOLES ON THE BACK OF EACH SIGNAL SECTION (4 SCREWS PER SECTION).

SEE MANUFACTURER RECOMMENDATION FOR TORQUE SETTING ON CABLE MOUNT CLAMP KITS.



555 N Zeeb Rd  
 Ann Arbor, MI 48103  
 734-761-1500

	Initials	Date
Created by	JDM	09/2003
Revised by	RLH	10/12/2023
Approved by	JPY	10/12/2023

TRAFFIC SIGNAL  
 INSTALLATION ON MAST ARM  
 (5 SECTION HEAD)

WASH-16

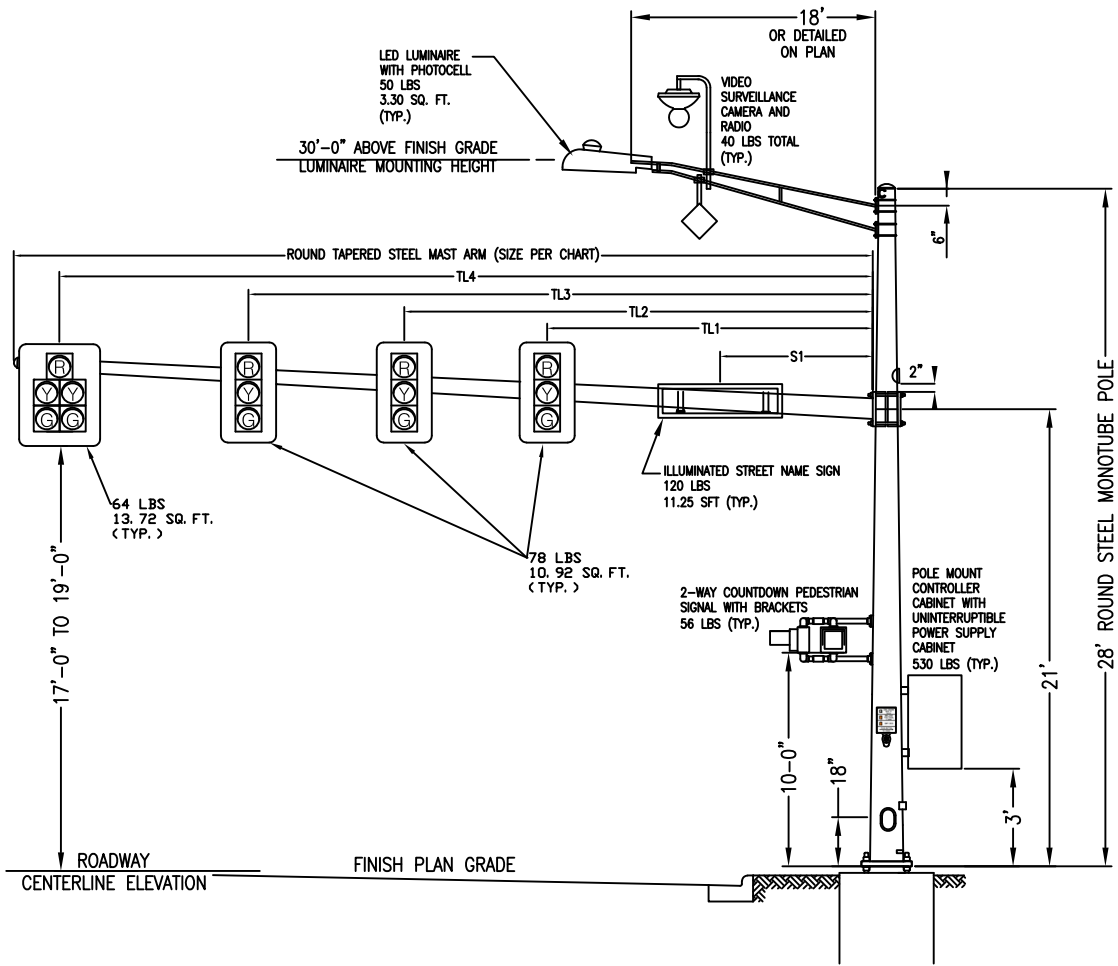

ARM SPREAD (FT.)	SIGNS & SIGNALS				
	TL1	TL2	TL3	TL4	S1
35'-0"	-	15'-0"	25'-0"	34'-6"	5'-0"
40'-0"	-	20'-0"	30'-0"	39'-6"	5'-0"
45'-0"	15'-0"	25'-0"	35'-0"	44'-6"	5'-0"
50'-0"	20'-0"	30'-0"	40'-0"	49'-6"	5'-0"
55'-0"	25'-0"	35'-0"	45'-0"	54'-6"	5'-0"

NOTES:  
 NO SCALE  
 SIGNAL HEAD AND EQUIPMENT CONFIGURATIONS ARE FOR LOADING PURPOSES ONLY.



555 N Zeeb Rd Ann Arbor, MI 48103 734-761-1500	Initials	Date
	Created by	JDM 09/2003
	Revised by	RLH 03/15/2024
	Approved by	JPY 03/15/2024

PEDESTAL FOR PEDESTRIAN PUSH BUTTON

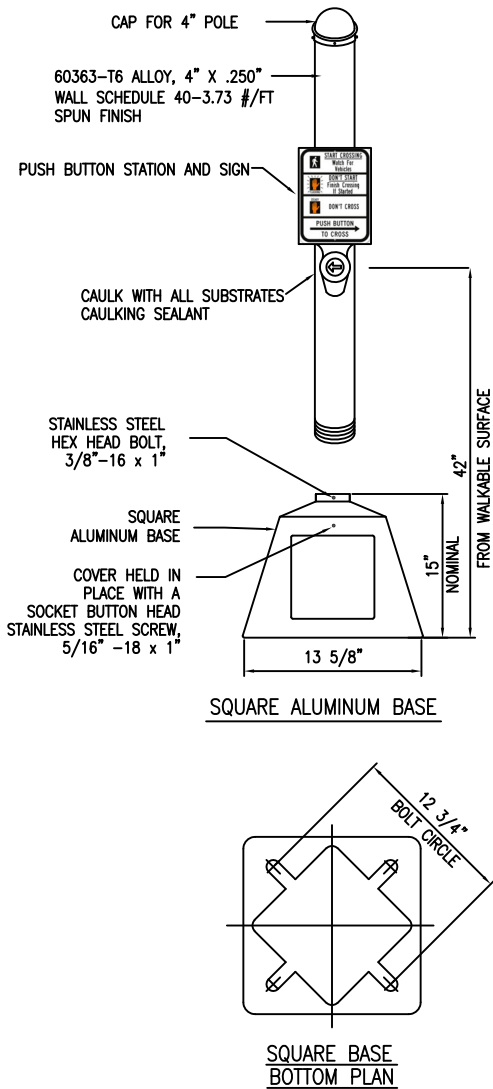

PEDESTAL FOUNDATION

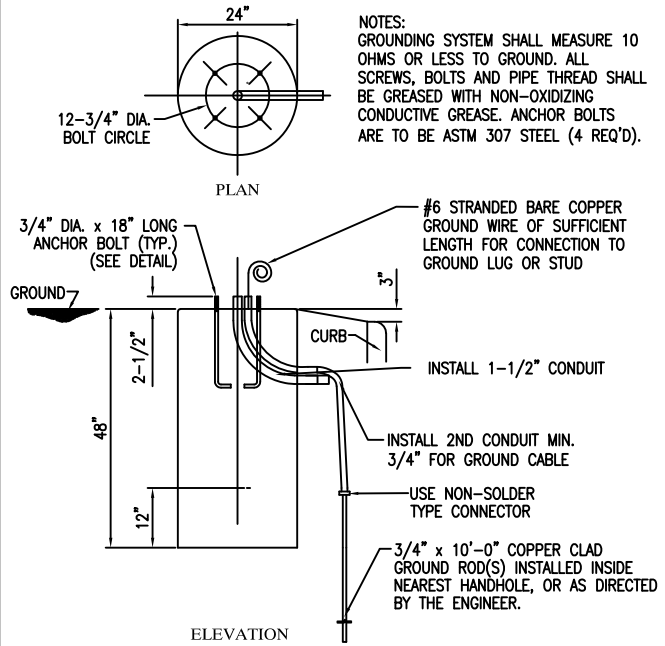

ANCHOR BOLT DETAIL

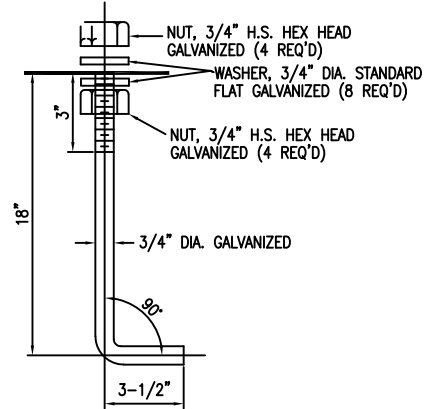

OPTIONAL PEDESTRIAN PUSH BUTTON FOUNDATION  
USING 48" PEDESTAL HELIX FOUNDATION

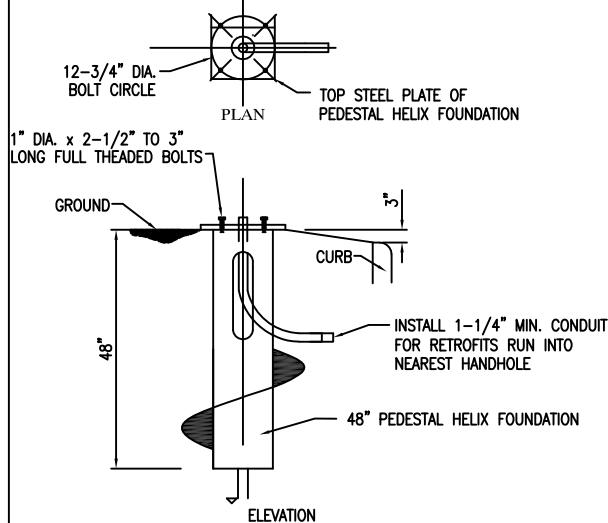

MOUNTING HARDWARE  
(ALTERNATE)

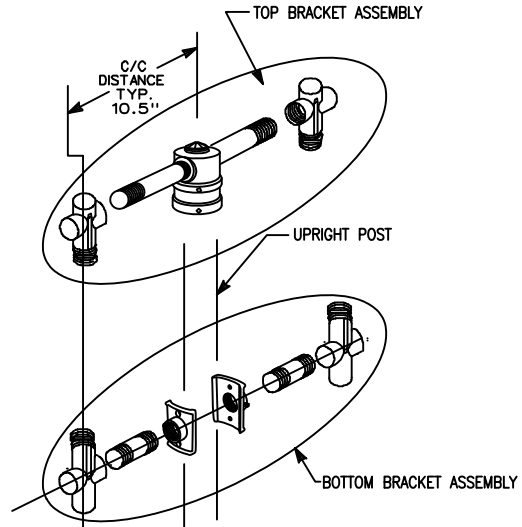

NOTE: NO SCALE.



555 N Zeeb Rd  
Ann Arbor, MI 48103  
734-761-1500

	Initials	Date
Created by	JDM	09/2003
Revised by	RLH	03/15/2024
Approved by	JPY	03/15/2024

PEDESTRIAN PEDESTAL, FOUNDATION  
& BRACKETING

WASH-18

ONE WAY MAST ARM MOUNTED CROSSWALK SIGN AND RRFB

USE ASTRO BRACKETS AND GUSSET TUBE TO ATTACH SIGN AND RRFB TO MAST ARM



W11-2 (SHOWN) (36" X 36") AND RRFB (SEE PLAN SHEET FOR SIGN TO BE INSTALLED)

DRILL 1-3/8" HOLE AND PLACE 1" INSIDE DIA. RUBBER GROMMET

8 FT ILLUMINATED (LED) CROSS WALK SIGN WITH BOTTOM (LED) STREET LIGHT CENTERED OVER ONE WAY MULTI LANES ROADS (ONE WAY ARM MOUNTED)

W11-2 (SHOWN) (36" X 36") (SEE PLAN SHEET FOR SIGN TO BE INSTALLED)

RECTANGULAR RAPID FLASHING BEACON (RRFB)

SEE SIGNS FOR RFB PAGE 3 DETAIL J

PUSH BUTTON STATION AND SIGN

SEE WASH-16, Pg 1-5 FOR MAST ARM STD. AND ARM DETAILS - CATEGORY III

RFB SYSTEM CABINET

ROUND STEEL MONOTUBE POLE AS PLANNED

19'

42" FROM WALKABLE SURFACE

FINISH PLAN GRADE

FOR FOUNDATION SEE MDOT MAST ARM STANDARD FOUNDATIONS (SIG-040-A)

NOTES:

1. NO SCALE
2. 18" MAXIMUM REACH FOR PUSH BUTTON FROM EDGE OF WALKABLE SURFACE
3. SPOKEN MESSAGE SHALL SAY "WARNING LIGHTS ARE FLASHING"



555 N Zeeb Rd  
Ann Arbor, MI 48103  
734-761-1500

	Initials	Date
Created by	JSW	02/2010
Revised by	RLH	03/15/2024
Approved by	JPY	03/15/2024

RRFB WITH MAST ARM POLE AND MAST ARM STD. - CATEGORY III

WASH-19

Page 1 of 4

TWO WAY MAST ARM MOUNTED CROSSWALK SIGN AND RRFB

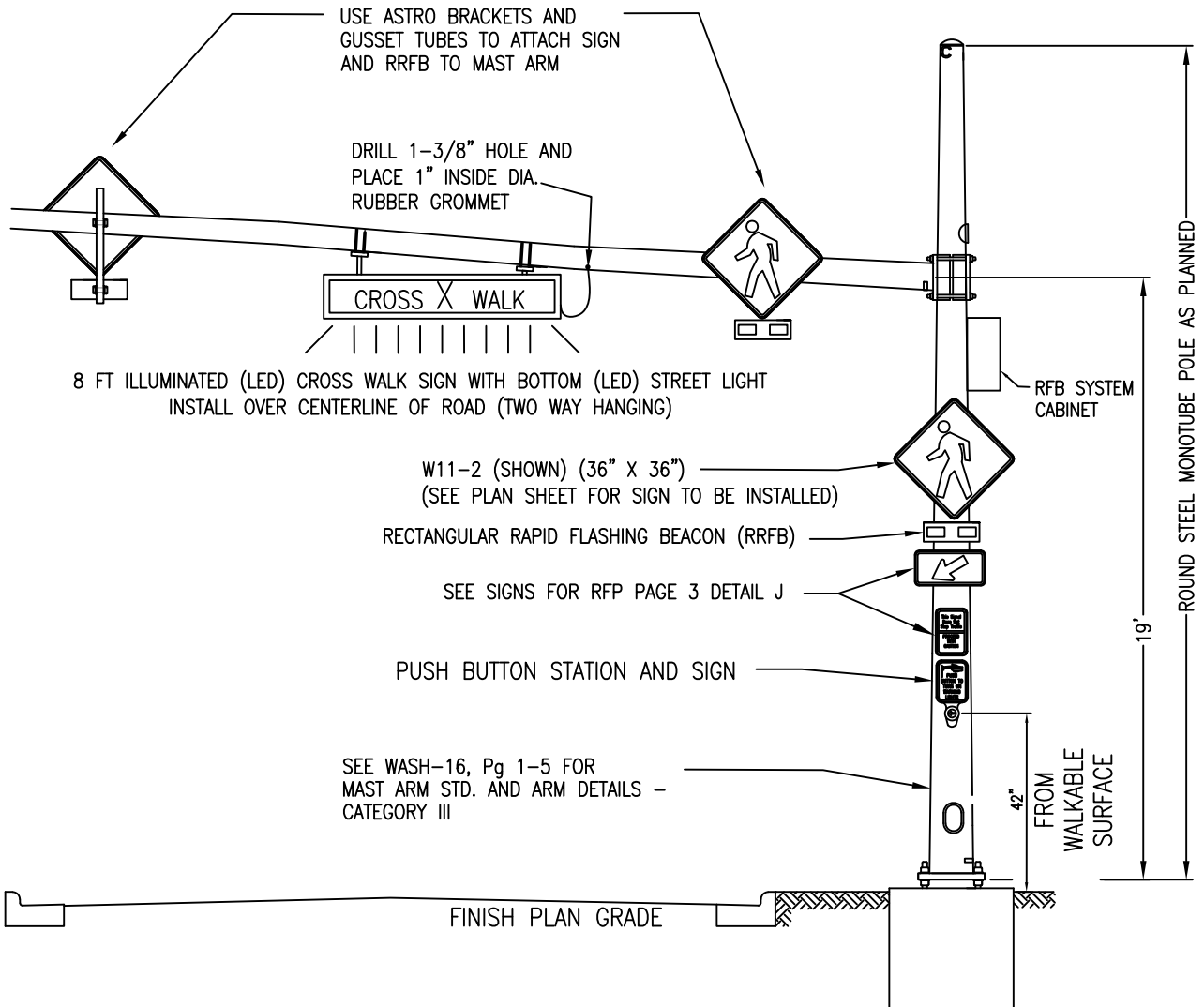

FOR FOUNDATION  
SEE MDOT MAST ARM  
STANDARD FOUNDATIONS (SIG-040-A)

NOTES:

1. NO SCALE
2. 18" MAXIMUM REACH FOR PUSH BUTTON FROM EDGE OF WALKABLE SURFACE
3. SPOKEN MESSAGE SHALL SAY "WARNING LIGHTS ARE FLASHING"



555 N Zeeb Rd  
Ann Arbor, MI 48103  
734-761-1500

	Initials	Date
Created by	JSW	02/2010
Revised by	RLH	03/15/2024
Approved by	JPY	03/15/2024

RRFB WITH MAST ARM POLE AND  
MAST ARM STD. - CATEGORY III

WASH-19

Page 2 of 4

**DETAIL J**

SIGN CODE W11-2 (SHOWN) (36"x36") FL Y/G  
 SEE PLAN SHEET FOR SIGN TO BE INSTALLED  
 INCLUDE SIGN BACK PLATE BETWEEN SIGN AND POLE  
 USE MDOT TYPICAL FOR HOLE SPACING

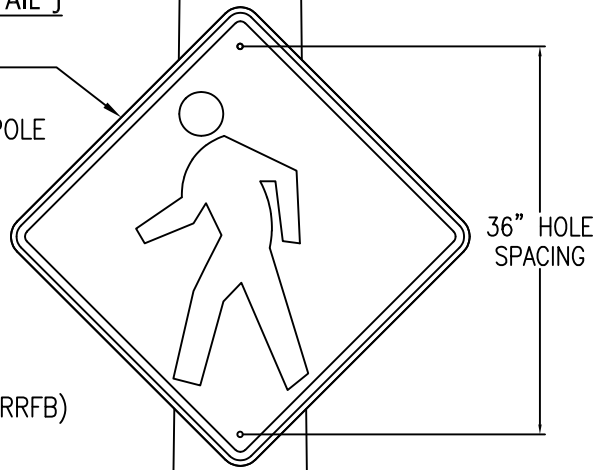

RECTANGULAR RAPID FLASHING BEACON (RRFB)

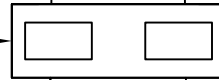

SIGN CODE W16-7PL (SHOWN)  
 OR W16-7PR (36"x18") FL Y/G  
 INCLUDE SIGN BACK PLATE BETWEEN SIGN AND POLE  
 USE MDOT TYPICAL FOR HOLE SPACING

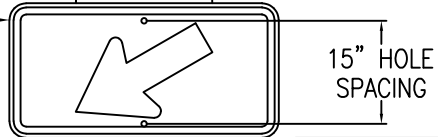

SIGN CODE SPECIAL (12"x18") Y/G

PUSH BUTTON STATION AND SIGN

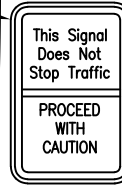

7' MIN. BOTTOM HEIGHT

42" FROM WALKABLE SURFACE

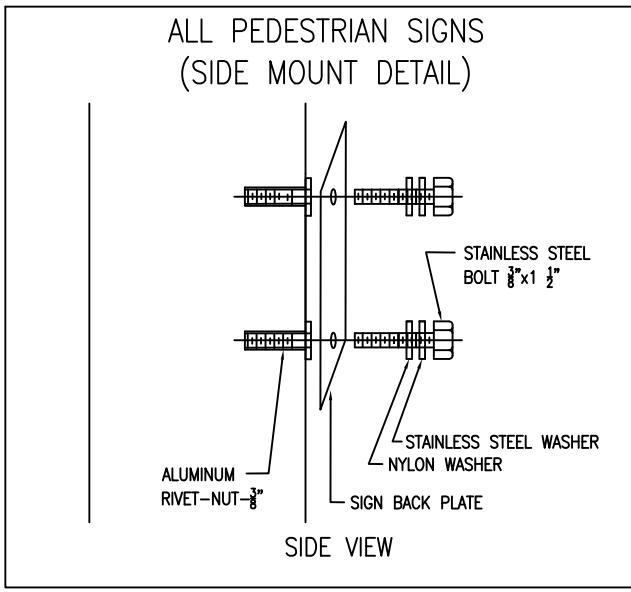

NOTES:  
 1. NO SCALE  
 2. 18" MAXIMUM REACH FOR PUSH BUTTON FROM EDGE OF WALKABLE SURFACE  
 3. SPOKEN MESSAGE SHALL SAY "WARNING LIGHTS ARE FLASHING"



555 N Zeeb Rd Ann Arbor, MI 48103 734-761-1500	Initials	Date
	Created by JSW	02/2010
	Revised by RLH	03/15/2024
	Approved by JPY	03/15/2024

PEDESTAL FOR PEDESTRIAN PUSH BUTTON

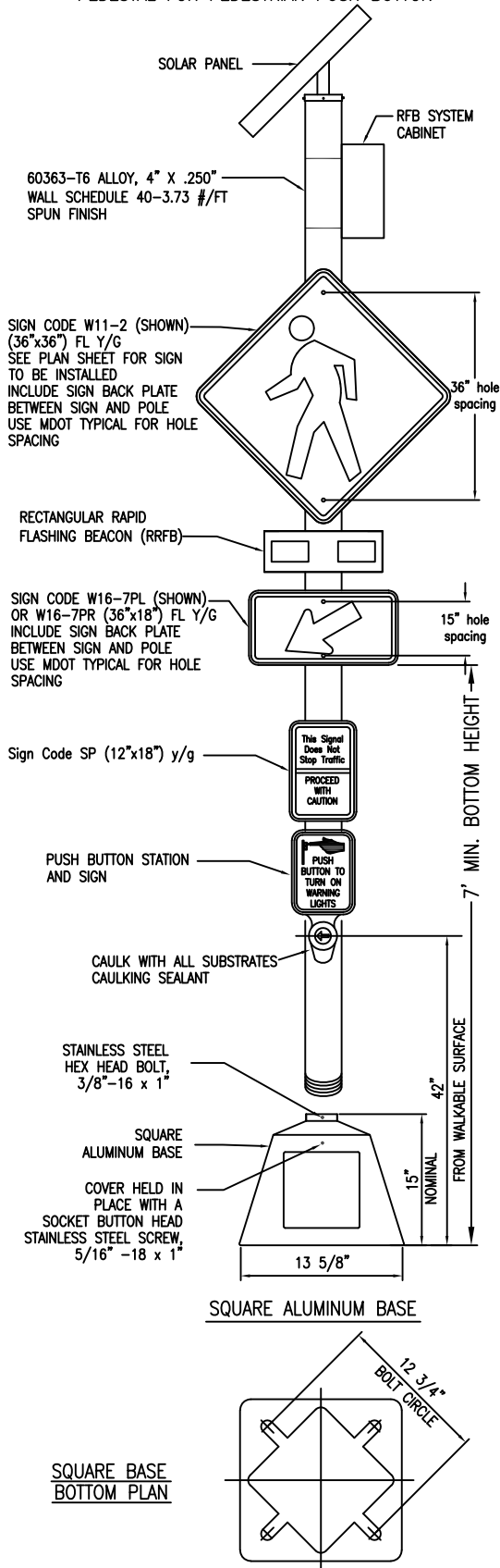

PEDESTAL FOUNDATION

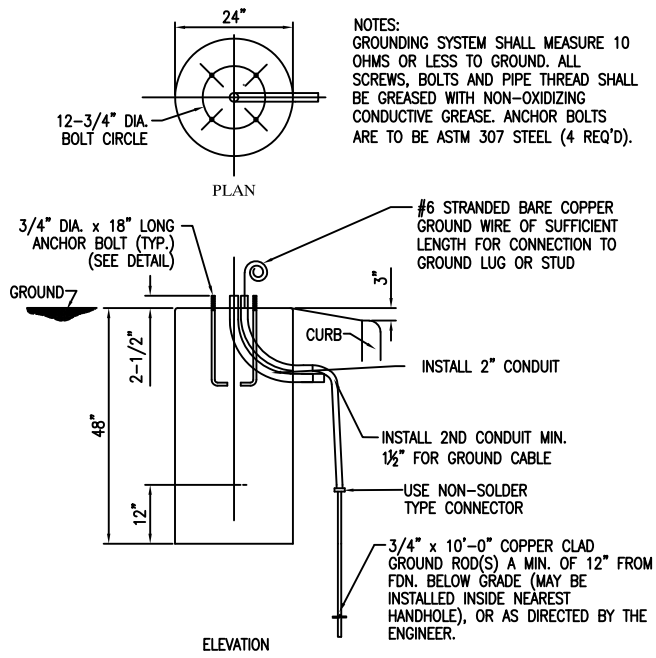

ANCHOR BOLT DETAIL

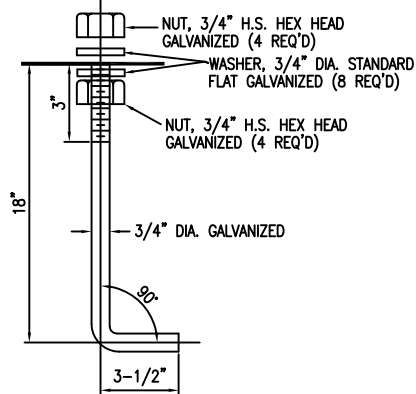

ALL PEDESTRIAN SIGNS (SIDE MOUNT DETAIL)

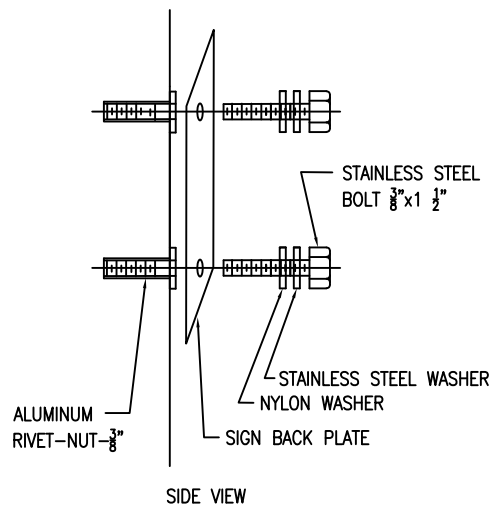

555 N Zeeb Rd Ann Arbor, MI 48103 734-761-1500	Initials	Date
	Created by	JSW 02/2010
	Revised by	RLH 03/15/2024
	Approved by	JPY 03/15/2024

RRFB WITH PEDESTRIAN PEDESTAL

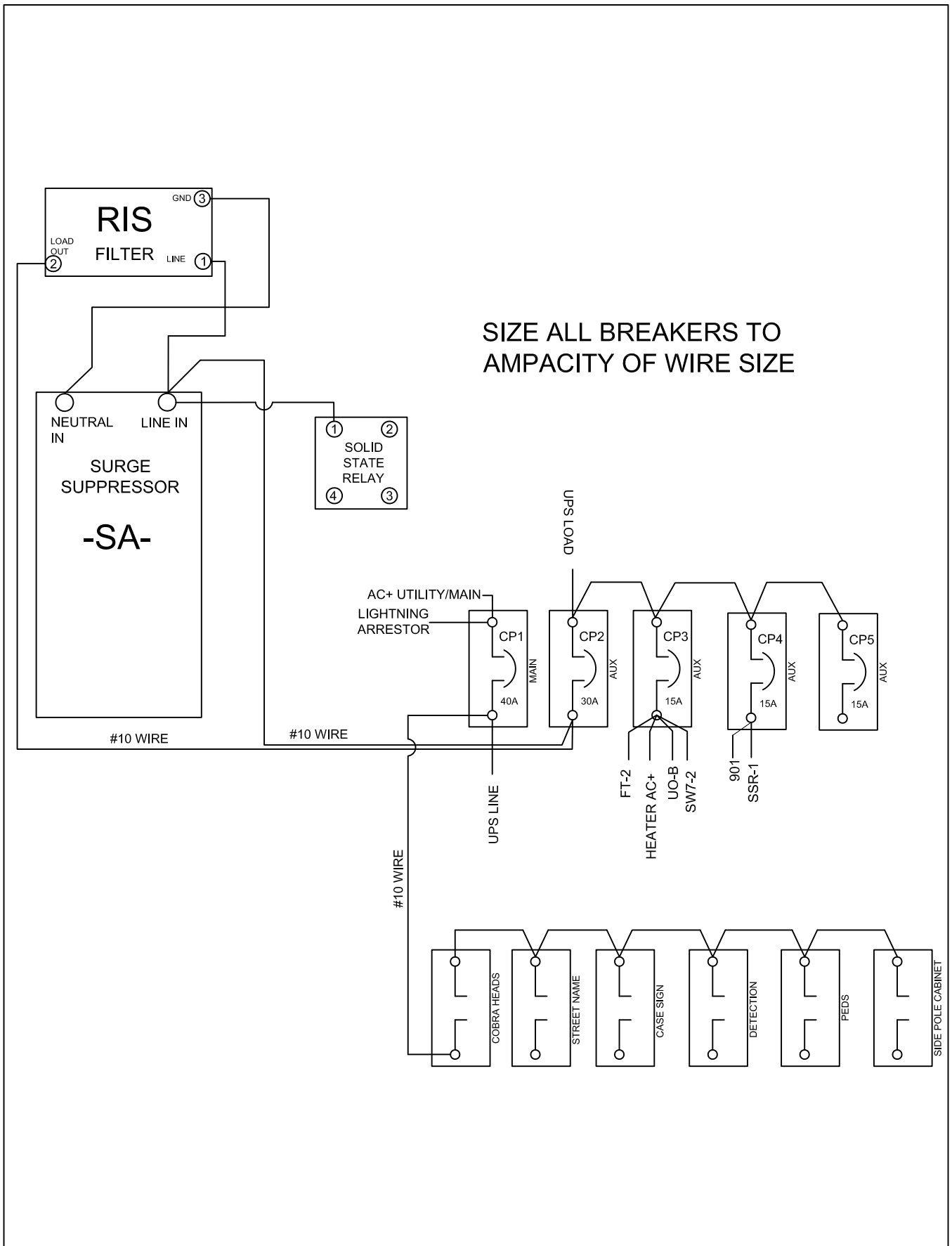

	555 N Zeeb Rd Ann Arbor, MI 48103 734-761-1500		Initials    Date	<b>UNINTERRUPTIBLE POWER SUPPLY STANDARD WIRING DIAGRAM</b>	WASH-20	Page 1 of 1
	Created by	RLH	02/2019			
	Revised by	RLH	10/16/2023			
	Approved by	JPY	10/16/2023			