

Bridge Painting: E. Delhi Rd and Maple (Foster) Rd

Virtual Public Information Meeting
April 7, 2022



  @Washtenawroads



Agenda

- I. Housekeeping
- II. Presentation
- III. Q and A



Today's Presenters



Nate Murphy, P.E.

Project Manager – Bridge Engineer

Direct: (734) 327-6647 | Main: (734) 761-1500

murphyn@wcroads.org

Today's Presenters



Aaron Berkholz, P.E.

Senior Project Manager – Design & Construction

Direct: (734) 327-6648 | Main: (734) 761-1500

berkholza@wcroads.org

Housekeeping



Meeting audio and video is being recorded and will be posted to wcroads.org



You will be asked to virtually “raise your hand” during Q and A



Chat is enabled



Bridge Painting: E. Delhi Rd and Maple (Foster) Rd

A Note on Historic Truss Bridges

- Unique to the area and built during a different era
- Fracture critical structures
 - Annual inspection
 - Weight limitations based on design
- Any work requires a full closure



Current State – E. Delhi Rd

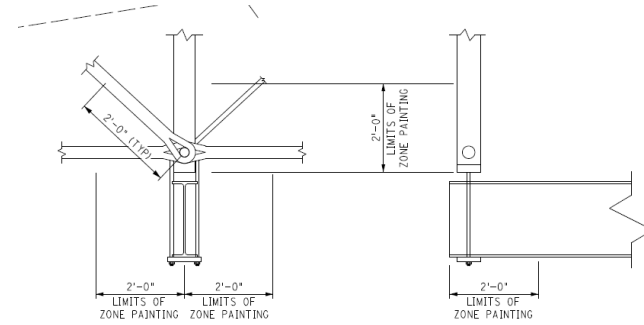

TYPICAL LOWER JOINT



Current State – E. Delhi Rd



Current State – E. Delhi Rd



The Plan – E. Delhi Rd Bridge

- Cleaning
- Repainting specific areas
 - Prevents rust/deterioration
 - Same paint color



Schedule

- **Proposed two-week closure starting in early July**
- **Dependent on...**
 - Weather (Humidity/Temperature)
 - Supply chain
 - Unexpected repairs

Schedule

- Why a full closure?
 - No room to maintain traffic and conduct work
 - Safety
 - Efficiency
 - River traffic will be closed during the work
 - Safety concerns
 - Expedite the work

Detour – E. Delhi Rd Bridge

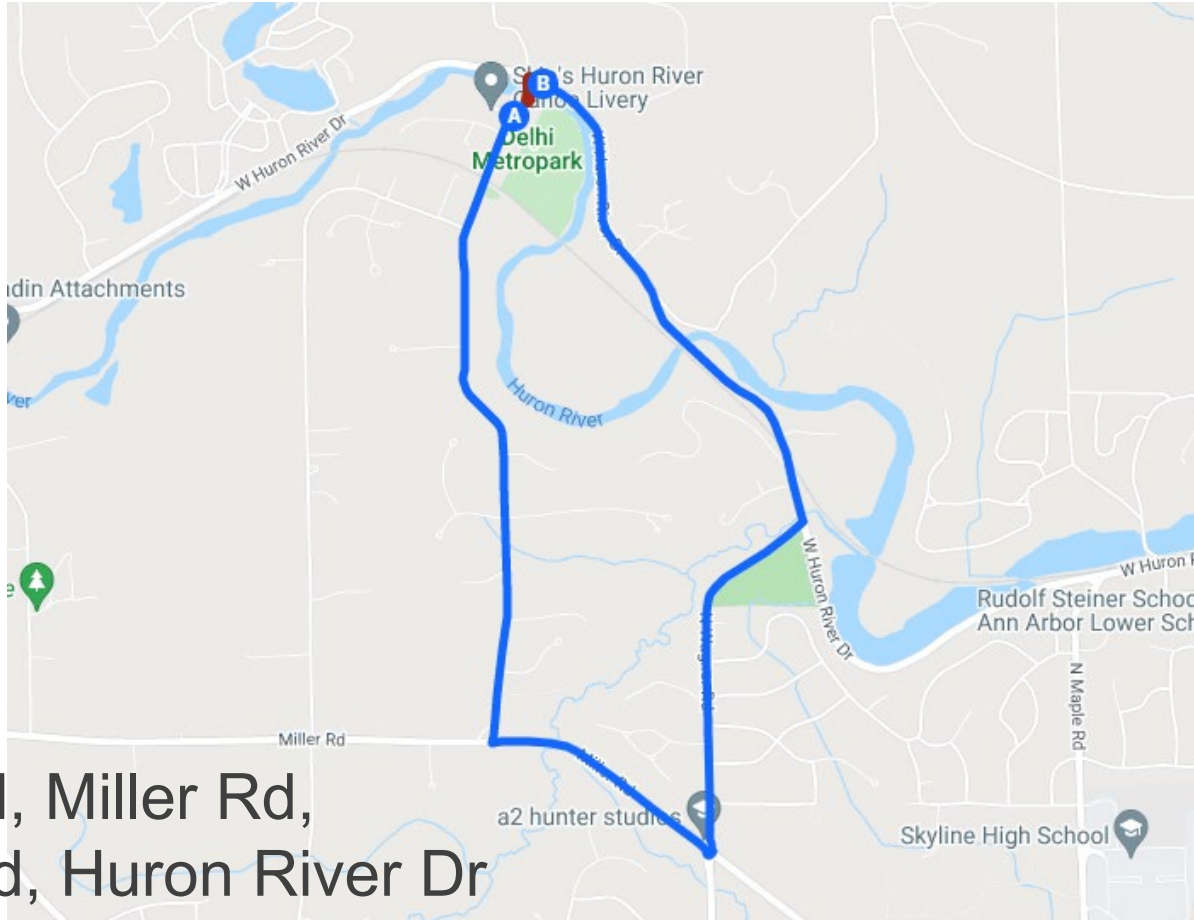

E Delhi Rd, Miller Rd,
Wagner Rd, Huron River Dr

Coordination

- Emergency services
- School buses
- MetroParks
- Skip's Canoe Livery
- Trash pickup
- Mail services





Bridge Painting: Maple (Foster) Rd

Current State – Maple (Foster) Rd



Current State – Maple (Foster) Rd



Current State – Maple (Foster) Rd



Current State – Maple (Foster) Rd



Current State – Maple (Foster) Rd



The Plan – Maple (Foster) Rd Bridge

- Set-up full enclosure
- Clean
- Repaint entire bridge
- Erosion control
- Drainage improvements
- Replace guardrail



Maple (Foster) Rd Bridge Paint

- Same paint color
- Why paint now?
 - Last painted in 2003
(prior to that 1978)
 - Prevents
rust/deterioration



Schedule

- **Proposed 12-week closure starting in early July**
- Dependent on...
 - Weather (Humidity/Temperature)
 - Supply chain
 - Unexpected repairs

Schedule

- Why a full closure?
 - No room to maintain traffic and conduct work
 - Safety
 - Efficiency
 - River traffic will be closed during the work
 - Safety concerns
 - Expedite the work



Detour – Maple (Foster) Rd Bridge

Huron River Dr,
N Delhi Rd,
W Joy Rd,
N Maple Rd

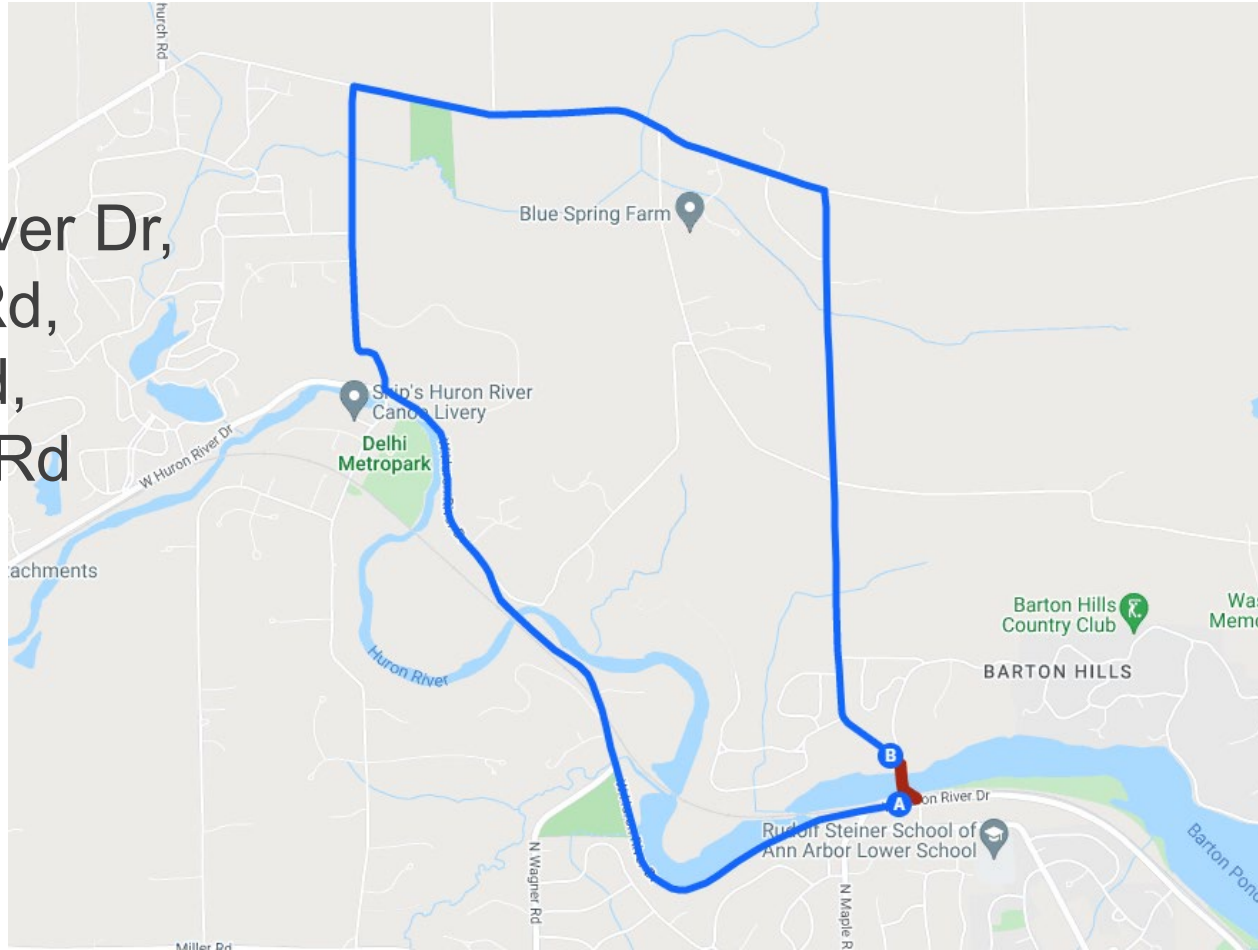

Coordination

- Emergency services
- School buses
- Trash pickup
- Mail services
- Advanced notice of closure
 - Message boards
 - Email advisory

Impact to Traffic

- Both bridges will be closed to **ALL** traffic during construction.



Project Coordination

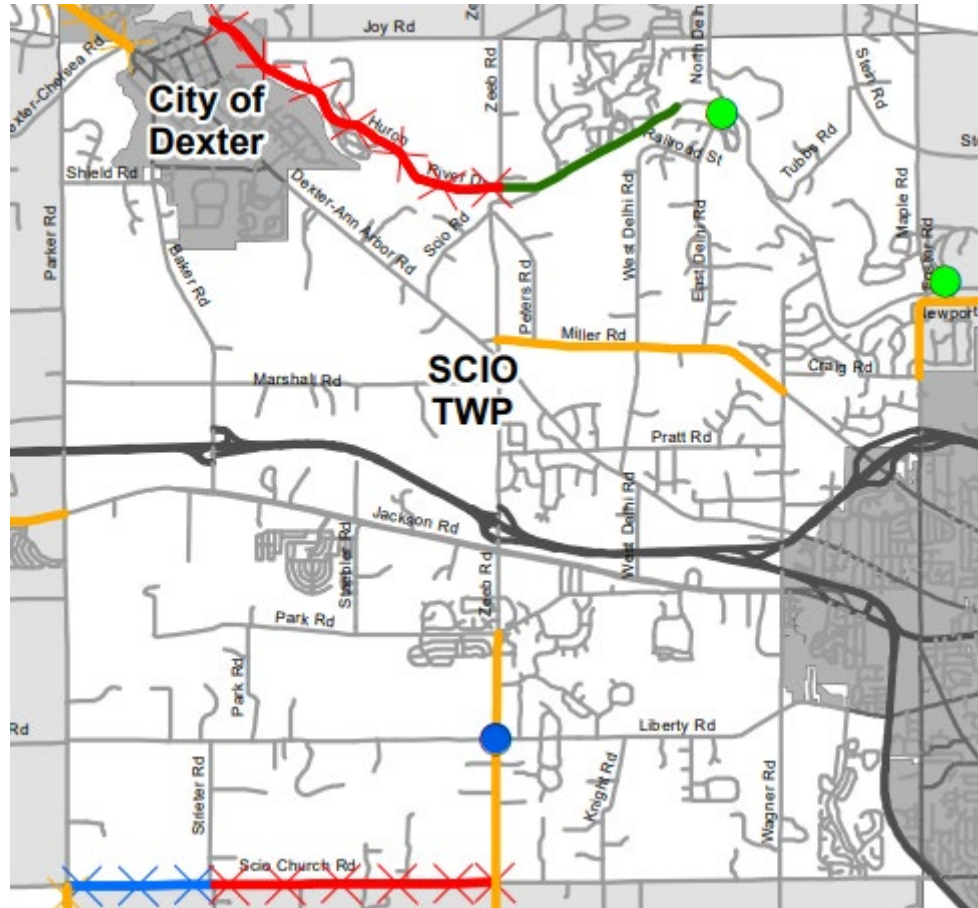

Legend - Project Type

- XXX Millage Project
- Mill/Overlay
- Pulverize/Overlay or Reconstruct
- Chipseal
- Limestone Overlay
- Non-Motorized Path
- Safety Project (sign upgrades & curve enhancement)
- Bridge/Culvert Project
- Intersection Project
- Safety Project

Find Out More

- **Visit project page @ wcroads.org**
 - Subscribe to receive project update emails
- **Contact Project Manager**
 - Nate Murphy, (734) 327-6647,
murphyn@wcroads.org



Q AND A



To Ask a Question

- On your computer or smart phone:
 - Join audio then click “participants” at the bottom of screen and select “raise hand”

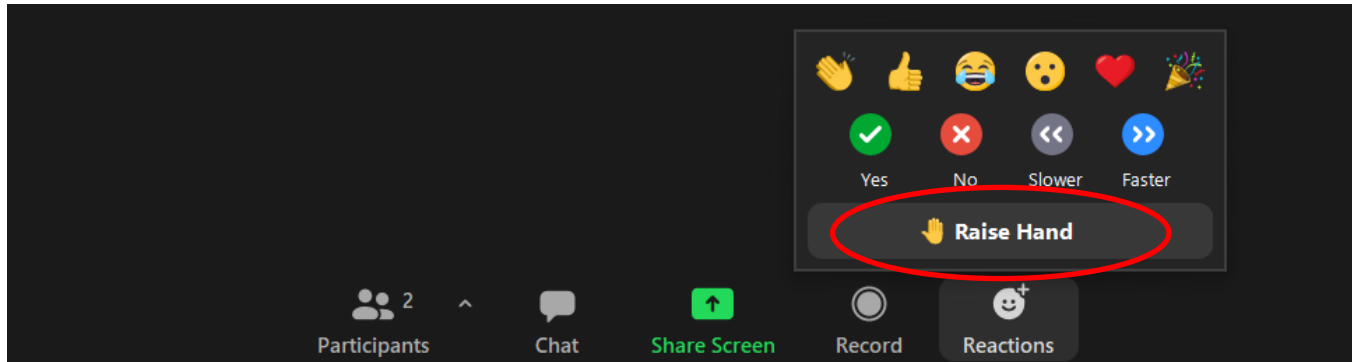

- On your touchtone phone: Dial *9

Find Out More

- **Visit project page @ wcroads.org**
 - Subscribe to receive project update emails
- **Contact Project Manager**
 - Nate Murphy, (734) 327-6647,
murphyn@wcroads.org