

WASHTENAW COUNTY ROAD COMMISSION
Bi-Monthly Meeting of the Board of County Road Commissioners

December 18, 2018 – 1:00 p.m.

Washtenaw County Road Commission Boardroom ♦ 555 N. Zeeb Road ♦ Ann Arbor, Michigan 48103

AGENDA

I. CALL TO ORDER/PLEDGE OF ALLEGIANCE

II. ELECTION OF OFFICERS

III. APPROVAL OF AGENDA

IV. ACCEPTANCE OF MINUTES (Action)..... Page 1-7

- A. Board Meeting Minutes of December 4, 2018
- B. Board Working Session Minutes of July 17, 2018

V. CITIZEN PARTICIPATION

This is the time set aside on the agenda to receive comments from the public. This is not intended to be a period for dialogue or questions and answers. Each person will be allotted (3) minutes to address the Board.

- A. Public Comment
- B. Written Communications..... **Page 8-10**

VI. NEW BUSINESS

A. Consent Agenda..... Page 11-50

- 1. Salem Township Right of Way Agreement – Chubb Road/Five Mile Road
- 2. Elimination of Redundant Policy – HR-19 (Loss of Drivers License)
- 3. Drug-Free Workplace Policy
- 4. 2019 Capital Equipment Purchase Authorization – 2020 International HV613 Truck Chassis
- 5. 2019 Capital Equipment Purchase Authorization – Wheel Loader
- 6. 2019 Capital Equipment Purchase – Tanker Trailer
- 7. 2019 Capital Equipment Purchase – Tractor Outfitting
- 8. 2019 Managed Services Provider (MSP) – Dominant Systems Corporation
- 9. Payroll & Bills December 12, 2018

B. Action Items

- 1. 2019 Board Meeting Schedule
- 2. 2019 Working Session Schedule
- 3. 2019 & 2020 Road Commission Appointments to WCP&RC, MTA/CEO, WATS

VII. REPORTS..... Page 51-55

- A. County Commissioner’s Report
- B. Road Commissioners’ Report
- C. Managing Director’s Report
 - 1. Staff Report of 11-26 to 12-9-18

VIII. EXECUTIVE SESSION

Collective Bargaining

IX. ADJOURNMENT

WASHTENAW COUNTY BOARD OF ROAD COMMISSIONERS

555 North Zeeb Road, Ann Arbor, MI 48103

Minutes of December 4, 2018

Board Present: Road Commissioners Douglas Fuller, Barbara Fuller, Rodrick Green

Staff Present: S. Siddall, J. Harmon, M. MacDonell, D. Ackerman, C. Ryan

Others Present: R. Jamnick, J. Stanowski, J. Peters, M. Brousseau, L. Moutinho, D. Rhoads

The meeting was called to order at 1:00 p.m. by Douglas E. Fuller, Chair. The Pledge of Allegiance was recited.

APPROVAL OF AGENDA

RC18-377 R. Green moved, B. Fuller seconded to approve the agenda as presented.
Voice Vote: YEAS: 3 NAYS: 0 ABSENT: 0 ABSTAIN: 0 Motion Carried.

PUBLIC HEARING – Road Commission 2019 Budget

Commissioner Doug Fuller declared the Public Hearing open.

No public comments were received.

Commissioner Doug Fuller closed the public hearing.

ACCEPTANCE OF THE MINUTES

RC18-378 B. Fuller moved, R. Green seconded, the Board hereby approves the Board Meeting Minutes of November 20, 2018 as presented. Voice Vote: YEAS: 3 NAYS: 0 ABSENT: 0 ABSTAIN: 0 Motion Carried.

RC18-379 R. Green moved, B. Fuller seconded, the Board hereby approves the Board Working Session Minutes of November 20, 2018 as presented. Voice Vote: YEAS: 3 NAYS: 0 ABSENT: 0 ABSTAIN: 0 Motion Carried.

PUBLIC COMMENT

Tree Removal

Ms. Mercedes Brousseau addressed the Board requesting that a very large tree be removed by the Washtenaw County Road Commission at her property located at 6371 North Maple Road in Saline. She stated this tree is within the Road Commission’s road right-of-way. Ms. Brousseau stated that she has also spoken to the District Forman regarding this tree. Ms. Brousseau requested verification be sent to her that she spoke to the Board regarding this matter.

Saline-Milan Road Bridge Replacement – waterflow

Mr. John Stanowski addressed the Board thanking the Road Commission for the very nice job paving Moon Road from Bemis Road to Willis Road. Mr. Stanowski was speaking on behalf of the Saline River Preserve regarding the Saline-Milan Road bridge replacement. Mr. Stanowski expressed concern of the waterflow across Saline-Milan Road and into the preserve. Mr. Stanowski asked if the Road Commission could put in a culvert to help divert water flow over Saline-Milan Road when this bridge is replaced.

WRITTEN COMMUNICATIONS

Sheryl Siddall, Managing Director, provided a review of the MDOT Local Bridge Advisory Board approval of bridges for the 2021 Local Bridge Program.

ISSUED: November 29, 2018
WHERE: Textile Road between State Road and Michigan Avenue (US-12)
TOWNSHIP: Pittsfield
WHY: Project partially completed
WHEN: Wednesday, November 28, 2018
CONTACT: Mark McCulloch, Sr. Project Manager

RECEIVED: November 29, 2018
FROM: Michigan Department of Transportation (MDOT)
WHY: MDOT Local Bridge Advisory Board approval of bridges for the 2021 Local Bridge Program
CONTACT: Aaron Berkholz, Sr. Project Manager

ISSUED: November 28, 2018
WHERE: Saline-Milan Road Bridge over the Koch Warner Drain on Saline-Milan Road near border of City of Saline
TOWNSHIP: York
WHY: Project announcement for Bridge replacement
WHEN: Summer and Fall of 2019
CONTACT: Aaron Berkholz, Sr. Project Manager

ISSUED: November 21, 2018
WHERE: Ellsworth Road between Carpenter Road and Golfside Road
TOWNSHIP: Pittsfield
WHY: Corrective work
WHEN: Tuesday, November 27th
CONTACT: Aaron Berkholz, Sr. Project Manager

CONSENT AGENDA

The items approved on the Consent Agenda are as follows:

RC18-380 B. Fuller moved, R. Green seconded the approval of the Consent Agenda for December 4, 2018 as presented. Voice Vote: YEAS: 3 NAYS: 0 ABSENT: 0 ABSTAIN: 0 Motion Carried.

Road Commission – 2018 Final Budget Amendments

RC18-381 B. Fuller moved, R. Green seconded that upon the recommendation of the Director of Finance and the concurrence of the Managing Director, the Board hereby approves the 2018 year-end budget as presented. Voice Vote: YEAS: 3 NAYS: 0 ABSENT: 0 ABSTAIN: 0 Motion Carried.

Payroll & Bills for November 28, 2018

RC18-382 B. Fuller moved, R. Green seconded the Board hereby approves Voucher 10326 totaling \$313,483.93 for payroll of November 14, 2018, and Voucher 10327 totaling \$914,447.91 in payment of bills for November 14, 2018. Voice Vote: YEAS: 3 NAYS: 0 ABSENT: 0 ABSTAIN: 0 Motion Carried.

ACTION ITEM

Road Commission 2019 Annual Budget

RC18-383 B. Fuller moved, R. Green seconded that upon the recommendation of the Director of Finance and the concurrence of the Managing Director, the Board hereby approves the Road Commission 2019 Annual Budget as presented. It is understood that the proposed 2019 budget supports 134 full-time equivalent positions. Voice Vote: YEAS: 3 NAYS: 0 ABSENT: 0 ABSTAIN: 0 Motion Carried.

REPORTS

COUNTY COMMISSIONER REPORT

No report.

ROAD COMMISSIONER REPORTS

Commissioner Barb Fuller

No report.

Commissioner Rod Green

No report.

Commissioner Doug Fuller

Commissioner Doug Fuller provided the Board a copy of House Bill No. 5945 that has been introduced by State Representative Donna Lasinski regarding agricultural trucking restrictions. Commissioner Fuller will contact State Representative Lasinski for clarification of House Bill No. 5945.

Commissioner Doug Fuller asked for a map of where County Parks is planning on developing trails within Washtenaw County.

Commissioner Fuller reported that there will be a ribbon cutting ceremony this coming Saturday for the Huron Waterloo Path Initiative at Werkner Road and M-52.

MANAGING DIRECTOR'S REPORT

Sheryl Siddall, Managing Director, reported that the TPOAM held a meeting last week and voted to not approve the tentative agreement. Sheryl will keep the Board advised of any updates from TPOAM.

LITIGATION UPDATE

Sheryl Siddall provided an update of legal cases with the Road Commission.

NE Service Center (FOIA Violation), Textile Road (condemnation case), Americans with Disability Act (City of Chelsea and AA Center for Independent Living), Dell Road (road defect).

OPERATIONS REPORT

Jim Harmon, Director of Operations

- Winter maintenance expenditures have been normal for the start of the season, but expected to be moderate for the remainder of the fiscal year

ENGINEERING REPORT

Matt MacDonell, Director of Engineering

- Matt introduced Nate Murphy as the new WCRC Bridge Engineer.
- Matt provided an update on the progress on the Sharon Valley Road bridge project.
- The Engineering Department staff is working on preparing contract documents (plans and specifications) for the 2019 road and bridge projects.

FINANCE & IT REPORT

Dan Ackerman, Director of Finance & IT

Finance Report

- Dan Ackerman thanked the board for approving the 2019 budget. This will allow our organization to continue to conduct business starting on January 1st.
- The 2017 state trunkline audit has started. Staff set up a SharePoint site to enable the Road Commission and the State of Michigan to more efficiently exchange information.

- The Finance Department is working on all year-end activities. This includes cutting off new purchases on December 9th. This will allow all invoices to be received and paid in a timely manner. The annual financial audit is one of the earliest in the state and will take place in late January or early February.
- Staff is also preparing all remaining invoices for 2018 work.

IT Report

- We are waiting on monitors that are on backorder. Once received, we can finish the rollout of laptops for the Engineering Department. This is all related to the SAW Grant.
- We are waiting on laptops for the foremen. Once received, we will provide training for all the foremen. This is related to the SAW grant.
- The IT Department is working on refining the onboarding process for new hires. The goal is to have a new employee's technology needs ready on their first day.

ADJOURNMENT

RC18-384 R. Green moved, B. Fuller seconded to adjourn the December 4, 2018 meeting at 2:15 p.m. Voice Vote: YEAS: 3 NAYS: 0 ABSENT: 0 ABSTAIN: 0 Motion Carried.

 Douglas E. Fuller, Chair

 Sheryl Soderholm Siddall, Deputy Clerk

Minutes Approved: _____

DRAFT

**WASHTENAW COUNTY BOARD OF ROAD COMMISSIONERS
WORKING SESSION MINUTES OF
July 17, 2018**

Present: Road Commissioners Douglas E. Fuller, Barbara Fuller

Staff Present: S. Siddall, J. Harmon, D. Ackerman, M. MacDonell, A Squire, C. Brochue, E. Kizer

Others Present: A. Philbrick, Karen Stickel and Jim Miller of Hubbel, Roth & Clark, R. Jannick

Commissioner Doug Fuller opened the Working Session at approximately 9:00 a.m.

Boland Corridor Quit Claim Deed (Dexter-Chelsea Road) – A. Philbrick

Sheryl Siddall provided a review of the Boland Corridor Quit Claim Deed issue. County Parks is moving ahead on this non-motorized path project from Freer Road to Lima Center Road. Not many outstanding issues or questions from City of Chelsea and residents along this corridor. The piece along Dexter-Chelsea Road east of Lima Center Road has not begun yet. The Road Commission has received letters from residents to quit claim this property to the property residents. Allen Philbrick provided a background and history on the Boland Corridor and stated not all properties along the Boland corridor have the same type of title. The residents that provided letters are on the easterly portion of Chelsea. Mr. Philbrick stated there needs to be consideration if there would be future use by the Road Commission for this easterly portion of the Boland Corridor. Sheryl Siddall stated there would be an option of quit claiming the Boland corridor property to the residents along this corridor in exchange for an additional 27 feet of road easement along this corridor that the Road Commission would maintain. The Board agreed for staff to issue a letter to the residents along the Boland Corridor requesting an additional 27 feet of road easement in exchange for quit claim deed to their property.

SAW Grant Presentation (Hubbel, Roth & Clark)

Sheryl Siddall stated that the Road Commission applied for a SAW grant in 2013. The Road Commission was recently awarded a \$1.2 million dollar SAW Grant for Asset Management for storm water systems throughout the county. Karen Stickel and Jim Miller provided a presentation of the awarded SAW grant.

PA 202 Application for Waiver and Plan (Pension & OPEB)

Dan Ackerman, Director of Finance & IT provided a background on PA 202. Last year the legislation made retiree healthcare and pensions a priority. Mr. Ackerman stated that we are required within six months of fiscal year end to file an initial financial report. We had until the end of June to submit initial forms which we did. Mr. Ackerman has communicated with MERS regarding this. Mr. Ackerman provided a review of the requirements of where the Road Commission funding stands for Pension & OPEB. Currently the Road Commission is underfunded for the Pension. We are considered underfunded because we are not categorized as a primary unit of government. We have submitted an application for waiver and plan for the pension & OPEB outlining the steps the Road Commission has taken towards being fully funded for the Pension & OPEB.

Miscellaneous Discussion Items

Commissioner Doug Fuller reported that he observed the West Willow area yesterday. Traffic at US 12 is traveling at excessively high rates of speed with another fatality on July 16th. Sheryl Siddall stated that she has had extensive conversations with MDOT on how to improve the safety in this area. The Road Commission will continue to work with MDOT to try to improve the safety in the West Willow area. A meeting with MDOT will be scheduled within the next 30 days.

County Commissioner Ruth Ann Jamnick stated her concerns at the intersection of exiting onto US 12.

ADJOURNMENT

B. Fuller moved, D. Fuller seconded to adjourn the July 17, 2018 Working Session at 11:30 a.m.
Voice Vote: YEAS: 2 NAYS: 0 ABSENT: 0 ABSTAIN: 0 Motion Carried.

Douglas E. Fuller, Chair
Washtenaw County Board of Road Commissioners

Bob Fuller, Chair
Washtenaw County board of Road Commissioners

COMMISSIONERS
DOUGLAS E. FULLER
CHAIR
BARBARA RYAN FULLER
VICE-CHAIR
RODRICK K. GREEN
MEMBER

WASHTENAW COUNTY
BOARD OF COUNTY ROAD COMMISSIONERS
555 NORTH ZEEB ROAD
ANN ARBOR, MICHIGAN 48103
WWW.WCROADS.ORG
TELEPHONE (734) 761-1500
FAX (734) 761-3737

SHERYL SODERHOLM SIDDALL, P.E.
MANAGING DIRECTOR
COUNTY HIGHWAY ENGINEER
MATTHEW F. MACDONELL, P.E.
DIRECTOR OF ENGINEERING
JAMES D. HARMON, P.E.
DIRECTOR OF OPERATIONS
DANIEL D. ACKERMAN
DIRECTOR OF FINANCE & IT

TO: Washtenaw County Board of Road Commissioners
FROM: Sheryl Soderholm Siddall, Managing Director
DATE: December 18, 2018
SUBJECT: **Written Communications for December 18, 2018 Board Meeting**

WRITTEN COMMUNICATIONS

ISSUED: December 7, 2018
WHERE: Chubb Road and Five Mile Road
TOWNSHIP: Salem
WHY: Reconstruction paving project on Five Mile Road from Chubb Road to Napier Road and Chubb Road from Five Mile Road to Six Mile Road
WHEN: After January 2019
CONTACT: Mark McCulloch, Sr. Project Manager

RECEIVED: December 2, 2018
FROM: Carol Westfall
WHY: Thank you to the Road Commission for all the help in improving the road conditions on Hieber Road

RECEIVED: December 3, 2018
FROM: Corrina Ruthig, Office/Financial Administrator for Michigan Concrete Association
WHY: Baker Road Roundabout project selected the winner in the Decorative Municipal category of the Michigan Concrete Association's Michigan Awards of Excellence.



Washtenaw County Road Commission
555 N. Zeeb Road
Ann Arbor, Michigan 48103

PROJECT ANNOUNCEMENT

Chubb Road and Five Mile Road Paving
December 7, 2018

The Washtenaw County Road Commission (WCRC), in partnership with Salem Township, is excited to announce a reconstruction project planned for the 2019 construction season on Five Mile Road from Chubb Road to Napier Road and on Chubb Road from Five Mile Road to Six Mile Road in Salem Township.

What will the improvement look like? WCRC, in partnership with Salem Township, will pave these sections of unpaved local roads. Once completed, the roads will become county designated routes (All-Season Roads) to better accommodate the commercial trucking that already exists along these corridors. Utilities will be relocated in advance of construction. Tree removal will also be conducted to achieve required grading and roadside drainage.

How is this project being funded? This is a township-initiated project based on the needs and desires identified by the surrounding community. Both roads are located within the township's Industrial District and are used daily by heavy industrial trucks. This project is funded by Salem Township and the business owners along the corridors.

When will this project be completed? To comply with environmental regulations protecting the Indiana Bat and the Northern Long-Eared Bats, tree removal will begin sometime after January and be completed before March 31, 2019. Utility relocation is expected to take place in the spring of 2019 as well.

Construction is expected to take place during the summer of 2019. It is estimated WCRC and its contractor will take four to five months to complete the project. Detour routes will be in effect to construct each roadway.

How can I get more information? Staff from WCRC will be presenting project details at the January 8, 2019, Salem Township Board of Trustees Meeting at Salem Township Hall. This meeting is open to the public.

In addition, WCRC will post project updates online at www.wcroads.org and on its Facebook and Twitter pages. Visit wcroads.org/residents/subscribe-to-road-updates/ to subscribe to project updates via email. For specific questions on this project, contact Mark McCulloch, project manager, at mccullochm@wcroads.org or (734) 327-6679.

From: Carol Westfall <carol_westfall@sbcglobal.net>
Sent: Sunday, December 02, 2018 6:16 PM
To: Fuller, Douglas <fullerd@wcroads.org>
Cc: Green, Rodrick <greenr@wcroads.org>; Fuller, Barbara <fullerb@wcroads.org>
Subject: Hieber Rd. Assistance

Doug Fuller --

I am writing to thank the Washtenaw County Road Commission for its help this past week on Hieber Rd. in Freedom Township.

Yesterday, December 1st, the Annual Manchester Christmas Home Tour was held out at Pleasant Lake. Four houses on Hieber Rd. and two houses on Pleasant Lake Rd. were on the tour and despite the "iffy" weather, we had approx. 180-200 visitors between 1pm and 8pm. Earlier in the week I had used WCRC Fix It to update the Road Commission on this event and to ask that Hieber Rd. be put into the best shape possible to make it easier for all these new visitors to drive on Hieber Rd. (yes, we get a lot of potholes!). Before the end of the week, my request was honored and the conditions on Hieber Rd. were significantly improved -- just in time for the Home Tour. THANK YOU so much!!!

Two things:

- 1) I suspect that Roark Freeman (Foreman for Yard 4) was responsible for responding to my WCRC Fix It request for help on Hieber. Please personally thank him for me!
- 2) I really like your WCRC Fix It communication tool. I have used it before and find it easy to use, and whoever is monitoring it is extremely responsive.

Many thanks ...

Carol Westfall
11268 Hieber Rd. (Freedom Township)
734-657-3880

COMMISSIONERS
DOUGLAS E. FULLER
CHAIR
BARBARA RYAN FULLER
VICE-CHAIR
RODRICK K. GREEN
MEMBER

WASHTENAW COUNTY
BOARD OF COUNTY ROAD COMMISSIONERS
555 NORTH ZEEB ROAD
ANN ARBOR, MICHIGAN 48103
WWW.WCROADS.ORG
TELEPHONE (734) 761-1500
FAX (734) 761-3737

SHERYL SODERHOLM SIDDALL, P.E.
MANAGING DIRECTOR
COUNTY HIGHWAY ENGINEER
MATTHEW F. MACDONELL, P.E.
DIRECTOR OF ENGINEERING
JAMES D. HARMON, P.E.
DIRECTOR OF OPERATIONS
DANIEL D. ACKERMAN
DIRECTOR OF FINANCE & IT

MEMO TO: Washtenaw County Board of County Road Commissioners
THROUGH: Sheryl Soderholm Siddall, P.E.
Managing Director
DATE: December 18, 2018
SUBJECT: **NEW BUSINESS ITEMS FOR DECEMBER 18, 2018 BOARD MEETING**

A. CONSENT ITEMS

1. Salem Township Right of Way Agreement – Chubb Road/Five Mile Road

Chubb Road between Five and Six Mile Roads, and Five Mile Road between Chubb Road and 1,800 feet west of Napier Road are local, gravel roads located in Salem Township. Salem Township approached the Road Commission with the desire to convert these roads to paved all-season roadways due to high volumes of commercial truck traffic and to eliminate dust issues. WCRC entered into an agreement with Salem Township in September of 2016, where the Township agreed to pay Bergmann Associates for preliminary engineering services and WCRC administration costs associated with the all-season roadway design. ROW needs have been identified for construction. Staff is ready to acquire these needs on behalf of the Township. This agreement will secure reimbursement from Salem Township to pay for ROW expenditures. The estimate to pave Chubb and Five Mile Roads is \$3.8 million.

PROPOSED MOTION: that upon the recommendation of the Director of Engineer and the concurrence of the Managing Director/County Highway Engineer, the Board hereby approves an agreement with Salem Township for Salem Township to pay for all right of way acquisition costs associated with paving Chubb Road between Five Mile and Six Mile Roads, and Five Mile Road from Chubb Road to Napier Road.

2. **Elimination of Redundant Policy – HR-19 (Loss of Drivers License)**

To assure that the Washtenaw County Road Commission continues to have an up-to-date database of applicable organizational policy's, the Human Resources Manager is proposing to eliminate the following policy because it is addressed in the updated Drug Free Workplace policy.

- Loss of Driver's License - HR-19

PROPOSED MOTION: that upon the recommendation of the Human Resources Manager, and with the concurrence of the Managing Director, the Board hereby rescinds policy HR-19.

3. **Drug-Free Workplace Policy**

To assure that the Washtenaw County Road Commission provides a safe, healthy and productive work environment for all employees, the Human Resources Manager is proposing a revised Drug-Free Workplace policy for All Employees.

PROPOSED MOTION: that upon the recommendation of the Human Resources Manager, and with the concurrence of the Managing Director, the Board hereby approves the Drug-Free Workplace Policy.

4. **2019 Capital Equipment Purchase Authorization – 2020 International HV613 Truck Chassis**

Staff is requesting the Board authorize the purchase of a new 2020 model year International HV613 truck chassis from Tri-County International Trucks, Inc. of Jackson, Michigan using the State of Michigan MIDEAL purchasing program (MIDEAL Contract # 071B6600122). In accordance with the attached quotation from Tri-County International dated November 29, 2018, for a total cost of \$111,363.00. Component upfitting will be presented for Board approval separately also using the State of Michigan MIDEAL Purchasing Program. The proposed equipment purchase is funded in the 2019 Capital Equipment budget.

PROPOSED MOTION: that upon the recommendation of the Director of Operations and the concurrence of the Managing Director, the Board hereby approves the purchase from Tri-County International Trucks, Inc., 3001 E. High Street, Jackson, Michigan, 49203 through the State of Michigan MIDEAL purchasing program of one new model year 2020 International HV613 truck chassis for the total cost of \$111,363.00.

5. 2019 Capital Equipment Purchase Authorization – Wheel Loader

Staff is requesting the Board authorize the purchase of a new 2019 Caterpillar 950M HL Wheel Loader from Michigan CAT using the State of Michigan MIDEAL purchasing program (MIDEAL Contract #071B7700084). This purchase will be assigned to District 3 at the Chelsea Yard. Purchase of the new loader includes the trade-in of an aged wheel loader, #844, 2003 Komatsu WA380-5L, 5,940 hours, S/N A52171, presently assigned to District 4 at the Manchester Yard. The District 3 current loader, #843, will be reassigned to District 4. Please reference attached quotation 140566-03 from Michigan CAT dated December 3, 2018 for the new wheel loader with accessories of \$289,672.00, less trade-in value in the amount of \$40,000. The final out-of-pocket purchase equals \$249,672.00. Purchase includes Caterpillar standard and extended warranties and guaranteed buybacks of 5 years/maximum 4,000 hours at \$160,000 or 10 years/maximum 6,000 hours at \$125,000. The proposed equipment purchase is funded in the 2019 Capital Equipment budget.

PROPOSED MOTION: that upon the recommendation of the Director of Operations and the concurrence of the Managing Director, the Board hereby approves the purchase from Michigan CAT of a new 2019 Caterpillar 950M HL Wheel Loader for the net cost after trade-in of \$249,672.00 through the State of Michigan MIDEAL purchasing program.

6. 2019 Capital Equipment Purchase – Tanker Trailer

Staff is requesting the Board authorize the purchase of a new 2019 Monroe 32' custom tanker trailer Model 32IAA-A from Truck & Trailer Specialties, Inc. of Howell, Michigan using the State of Michigan MIDEAL purchasing program (MIDEAL Contract # 071B5500010) in accordance with the attached quotation from Truck & Trailer Specialties dated December 10, 2018, for a total cost of \$106,134.00. The proposed equipment purchase is funded in the 2019 Capital Equipment budget.

PROPOSED MOTION: that upon the recommendation of the Director of Operations and the concurrence of the Managing Director, the Board hereby approves the purchase from Truck & Trailer Specialties, Inc., 1200 Victory Drive, Howell, Michigan, 48843 of a new 2019 Monroe custom tanker trailer for the total cost of \$106,134.00.

7. 2019 Capital Equipment Purchase – Tractor Outfitting

Staff is requesting the Board authorize the purchase of wet kit outfitting for an International HV613 truck chassis from Truck & Trailer Specialties, Inc. of Howell, Michigan using the State of Michigan MIDEAL purchasing program (MIDEAL Contract # 071B5500010) in accordance with the attached quotation from Truck & Trailer Specialties dated December 10, 2018, for a total cost of \$18,210.00. The proposed equipment purchase is funded in the 2019 Capital Equipment budget.

PROPOSED MOTION: that upon the recommendation of the Director of Operations and the concurrence of the Managing Director, the Board hereby approves the purchase from Truck & Trailer Specialties, Inc., 1200 Victory Drive, Howell, Michigan, 48843 of wet kit outfitting for an International HV613 truck chassis for the total cost of \$18,210.00.

8. 2019 Managed Services Provider (MSP) – Dominant Systems Corporation

Staff has worked with Dominant Systems Corporation (DSC) for several years in various capacities. Their role expanded in 2018 and they have taken an active role in several recommended initiatives. These initiatives are substantially complete and have moved the organization's infrastructure, software, hardware and security protections forward.

Halfway through 2018, the Road Commission hired a System Administrator to provide an internal presence. This individual has learned from DSC and is familiar with nearly all aspects of the Road Commission's hardware and software. The System Administrator's institutional knowledge will allow the agency to transition Dominant's role to a Managed Services Provider relationship. There are so many complex systems and technology is changing at a rapid pace, making it a necessity to have a MSP working in conjunction with internal staff. Dominant will be able to proactively monitor all systems on a daily basis and assist staff with anticipating any problems.

PROPOSED MOTION: that upon the recommendation of the Director of Finance and IT and the concurrence of the Managing Director, the Board hereby approves a Managed Services Provider contract for 2019 with Dominant Systems for a not to exceed amount of \$120,000.00.

9. Payroll & Bills for December 12, 2018

Staff is requesting the Board to approve the payment of payroll and bills for December 12, 2018.

PROPOSED MOTION: the Board hereby approves Voucher 1028 totaling \$288,863.74 for payroll of December 12, 2018, and Voucher 10329 totaling \$2,833,180.26 in payment of bills for December 12, 2018.

B. ACTION ITEMS

1. 2019 Board Meeting Schedule

Staff is requesting that the Board approve the 2019 Board Meeting Schedule for the first and third Tuesday of each month at 1:00 p.m.

PROPOSED MOTION: the Board hereby adopts the 2019 Board Meeting Schedule (attached hereto and made part of these minutes), which will take place on the first and third Tuesday of each month at 1:00 p.m. in the Board Room at the Road Commission office at 555 N. Zeeb Road, Ann Arbor, Michigan.

2. 2019 Working Session Schedule

Staff is requesting the Board to approve the 2019 Working Session Schedule to be held at approximately 9:00 a.m. on the third Tuesday of each month.

PROPOSED MOTION: the Board hereby approves the 2019 Working Session Schedule (attached hereto and made part of these minutes) to be held at approximately 9:00 a.m. on the third Tuesday of each month in Conference Room No. 200 at the Road Commission office at 555 N. Zeeb Road, Ann Arbor, Michigan.

3. 2019 & 2020 Road Commission Appointments to WCP&RC, MTA and WATS

The Board hereby appoints Commissioner _____ to serve as Road Commission representative on the Washtenaw County Parks & Recreation Commission, Commissioner _____ to serve as Road Commission representative on the Michigan Township Association, Commissioner _____ to serve as Road Commission representative on the Policy Committee of the Washtenaw Area Transportation Study. These appointments are for the calendar year 2019/2020.

CHUBB ROAD AND FIVE MILE ROAD

RIGHT-OF-WAY AGREEMENT

BETWEEN SALEM TOWNSHIP AND

THE WASHTENAW COUNTY ROAD COMMISSION

This Agreement ("Agreement"), is entered into as of the ___ day of _____, 2018, by and between by the Board of County Road Commissioners of the County of Washtenaw, a public body corporate, with offices at 555 Zeeb Road, Ann Arbor, Michigan 48103 ("**WCRC**") and Salem Township, a public body corporate, with offices at 9600 Six Mile Road, Salem, MI 48175 (the "**TOWNSHIP**").

WHEREAS, The Township desires for Chubb Road between Five Mile Road and Six Mile Road, and Five Mile Road between Chubb Road and Napier Road, to be paved roadways (the "**PROJECT**"), and

IT IS NOW THEREFORE AGREED, the Township will be responsible for all costs associated with right-of-way purchases ("**ROW**") to construct the Project, however, all offers for ROW acquisition will first be presented to the Township for approval and

IT IS FURTHER AGREED, during ROW negotiations, the WCRC shall provide the following to the Township Supervisor: (1) ROW updates as needed; (2) Individual ROW offers made to property owners to secure property for the project, and

IT IS FURTHER AGREED that WCRC will oversee the Project and project will proceed in accordance with current Federal Highway Administration and Michigan Department of Transportation practices and procedures for purchasing ROW. WCRC will coordinate the preparation of ROW documents and secure the required easements or ROW and grading permits for the Project, and

IT IS FURTHER AGREED that WCRC will periodically issue invoices to the Township for payment of Project costs associated with the purchase of ROW that exceed the funds submitted by the Township for the paving of Chubb Road and Five Mile. WCRC shall provide documentation to the Township of all costs incurred for the ROW, and

IT IS FURTHER AGREED that the Township shall make payment within thirty (30) days of receipt of invoices issued by WCRC as described herein. The Township will be responsible for any and all actual costs to purchase ROW and secure grading permits, including WCRC and/or consulting staff time to secure ROW.

IN WITNESS WHEREOF, the parties have set their hands to this Agreement the day and year here written.

SALEM TOWNSHIP

Dated: _____, 2018

By: Gary Whittaker, Salem Township
Its: Supervisor

**BOARD OF COUNTY ROAD COMMISSIONERS OF THE
COUNTY OF WASHTENAW**

Dated: _____, 2018

By: Sheryl Soderholm Siddall
Its: Managing Director

Dated: _____, 2018

By: Douglas E. Fuller
Its: Board Chair

	ORGANIZATIONAL POLICY	GENERAL ADMINISTRATION APPLICATION: Non-Union Employees			
TITLE: Loss of Drivers License	RESOLUTION NUMBER RC97-431	SUPERCEDE	EFFECTIVE DATE 09/02/1997	SUPERCEDE	POLICY NUMBER HR-19

INTENT

To provide accommodations to employees who lose their driving licenses because of drug or alcohol use if employees agree to participate in the Drug Free Workplace Program.

PURPOSE

If an employee loses his or her required driver's license due to the use of controlled substances or alcohol, and the employee agrees to participate in the employer's Drug Free Workplace Program, he or she will be permitted to remain in his or her current position for a minimum of thirty (30) days. After the 30 days, he or she will be permitted to fill a temporary position for a period of up to twelve (12) months or until he or she obtains a valid driver's license, whichever comes first. The grade of the position will be based on the job responsibilities which the employee is capable of performing. At the end of twelve (12) months a review of his or her job performance will be made to determine what further action needs to be taken. These provisions do not protect an employee due to layoff, involuntary transfer or demotion caused by a reduction in the workforce.

 ORGANIZATIONAL POLICY	GENERAL OPERATIONS APPLICATION: All Employees				
	TITLE: Drug-Free Workplace	RESOLUTION NUMBER RCXX-XX	SUPERCEDE RC92-314	EFFECTIVE DATE MM/DD/YYYY	SUPERCEDE 08/31/1992

INTENT

It is the intent of the Washtenaw County Board of Road Commissioners to provide a safe, healthy and productive work environment for all Washtenaw County Road Commission (WCRC) employees. Consistent with this commitment and in accordance with the Federal Drug Free Workplace Act the manufacturing, unauthorized use or possession, sale or distribution of illegal drugs/alcohol by WCRC employees while on duty or on Road Commission property is strictly prohibited.

PROHIBITIONS

- A. Alcohol concentration. No employee shall report for duty or remain on duty requiring performance of safety-sensitive functions while having an alcohol concentration of 0.02 or greater.
- B. Possession of Alcohol or a Prohibited Substance. No employee shall be on duty or operate a commercial motor vehicle while the employee possesses alcohol or a prohibited substance.
- C. On-duty use. No employee shall use alcohol or a prohibited substance while on duty.
- D. Pre-duty use. No employee shall perform safety-sensitive functions within four hours after using alcohol or while under the influence of a prohibited substance.
- E. Use following an accident. No employee required to take a post-accident test shall use alcohol for eight hours following the accident, or until he/she undergoes a post-accident alcohol test, whichever occurs first.
- F. Refusal to submit to a required alcohol or controlled substances test. No employee shall refuse to submit to an alcohol or controlled substances test required under this policy.

TESTING CONDITIONS

- A. Pre-Employment – All approved applicants for employment with the Road Commission shall be given a blood and/or urine test for prohibited substances coincidental with a pre-employment physical. Those testing positive shall not be

hired.

- B. Reasonable Suspicion – An employee of the Road Commission may be ordered to submit to testing upon reasonable suspicion that such an employee may be under the influence of alcohol or prohibited substances while working or while at the workplace.
- C. Post-Accident – Any employee involved, while operating equipment, in a reportable accident. A “reportable accident” means an accident:
 - 1) involving the loss of human life;
 - 2) resulting in bodily injury to a person who, as a result of the injury, immediately receives medical treatment away from the scene of the accident, and/or the employee receives a citation within 8 hours of the accident, or;
 - 3) one or more of the motor vehicles incurs disabling damage as a result of the accident, requiring the vehicle to be transported away from the scene by tow truck or other vehicle, and/or the employee receives a citation within 8 hours of the accident.
- D. Return to Duty/Follow-Up – Any employee participating in an approved substance abuse evaluation drug and alcohol program as described in Section VI shall be tested at such intervals as recommended by the Substance Abuse Professional. The employee is responsible for the cost of this testing.
- E. Random – Employees in designated positions that require a Commercial Driver’s License (CDL) will be subject the random selection process.

TESTING REQUIREMENTS

- A. All breath, blood and/or urine examinations will be performed by a certified testing facility recognized under the U.S. Department of Transportation’s current rules and which is accessible through the Employer’s current designated medical facility.

- B. Samples testing positive for one of the designated controlled substances under the U.S. Department of Transportation's guidelines shall be subjected to an additional confirmatory gas chromatography mass spectrometry (GC/MS) test. No urine test shall be reported positive until confirmation by such GC/MS testing. In addition, the laboratory shall retain a portion of the initial sample to be made available on request for independent confirmatory tests at the employee's expense.
- C. Collection and processing procedures for the types of test covered by this policy shall be done substantially in accordance with those procedures in 49 CFR Part 40 to ensure that samples are not tampered with during or after collection.

The confirmatory positive test result "cut-off" levels shall be as provided in 49 CFR 40.87(a) and as set out in the following table:

Cutoff Concentrations for Drug Tests		
	Initial Test	Confirmatory Test
Marijuana Metabolite	50 ng/ml	15 ng/ml
Cocaine Metabolite	150 ng/ml	150 ng/ml
Codeine/morphine	2000 ng/ml	2000 ng/ml
Hydrocodone/hydromorphone	300 ng/ml	100 ng/ml
Oxycodone/oxymorphone	100 ng/ml	100 ng/ml
6-Acetylmorphine	10 ng/ml	10 ng/ml
Phencyclidine	25 ng/ml	25 ng/ml
Amphetamine/methamphetamine	500 ng/ml	250 ng/ml
MDMA/MDA	500 ng/m	250 ng/ml
Adjustments in the Federal test levels will occur on the effective date thereof.		

- D. Only specimens confirmed as positive by the GC/MS test procedure shall be reported as positive for controlled substances by the testing laboratory. Test results shall be reported to the Medical Review Officer substantially in accordance with the procedures set out in 49 CFR 40.97. The Medical Review Officer shall review the results reported from the laboratory substantially in accordance with the procedures set out in 49 CFR 40.127 through 40.151.
- E. Tests for alcohol levels shall be considered to verify that the employee is under the influence when the blood/alcohol level meets, or exceeds, .02%. Any employee who provides a positive alcohol test result of .02% or greater, but less than .04%, shall be mandated to wait a minimum of twenty-four (24) hours prior to again reporting for duty.
- F. Before reporting test results to the Road Commission, the Medical Review Officer shall ascertain from records made available, and from the employee during the interview, whether an employee who has tested positive for a controlled substance is, or has been, taking prescription or nonprescription medication prior to furnishing the test sample. The Medical Review Officer shall make the decision as to whether such medications used prior to collection of the test sample render a positive result unreliable. If the employee claims that a medication has been prescribed, and a positive test result is reported to the

Medical Review Officer, the Medical Review Officer shall require that employee to furnish evidence such medication was, in fact, prescribed for the employee. Such evidence shall include a copy of a prescription written by a licensed physician or other documentation, such as a notation in an employee's medical records, indicating such a medication was prescribed. The Medical Review Officer shall not consider prescription medicine taken without a prescription as an excuse in determining whether or not a test result should be attributed as positive.

ACTIONS

- A. Alcohol test results. A screening test of less than 0.02 will be considered "negative" and the employee may return to work. In the event a test registers 0.02 or greater, the employee will be required to take a confirming test. If the confirming test registers less than 0.02, the test will be considered negative and the employee may return to work.

If the confirming test registers 0.02 or greater but less than 0.04, the employee may return to non-safety-sensitive jobs within twenty-four hours following the time of the confirming test. He/she will not be eligible for emergency call-in or scheduled overtime during that period. [If this situation (having a positive confirming test of 0.02 or greater) occurs more than once in any twelve-month period, Section IV of this "Drug-free Workplace Policy" will be implemented.]

If the employee tests 0.04 or greater on the confirming test, then Section VI of this "Drug-free Workplace Policy" will be implemented. Even if the Substance Abuse Professional clears the employee for return to work, he/she cannot return to a safety-sensitive job for twenty-four hours from the time of the positive test, nor will he/she be eligible for emergency call-in or scheduled overtime during that period. In order to return to work, the employee must provide a test from a certified Breath Alcohol Technician (BAT) proving less than 0.02 alcohol concentration within four hours of the time of their return to the job.

- B. Drug test results. Employees receiving a positive drug screen report from the Medical Review Officer will be removed from the job and Section VI of this "Drug-free Workplace Policy" will be implemented
- C. Costs. Employees must bear the cost of any follow-up or return to work tests after a positive result has been given.

SUBSTANCE ABUSE EVALUATION

- A. In the event that testing shall reveal the presence of either alcohol or prohibited substance in such employee's breath, blood and/or urine at the time of testing beyond the accepted levels, that employee shall be required to submit to an immediate evaluation by an approved Substance Abuse Professional for possible alcohol and/or substance abuse problems. Pending such evaluation, the employee shall be placed on immediate suspension without pay. After the evaluation such employee shall be required, as a condition of continued

employment, to enter and participate in such treatment programs as shall be recommended by the Substance Abuse Professional and shall be placed upon medical leave of absence, without pay, except to the extent that such employee shall use accumulated sick time or vacation time during such medical leave of absence.

- B. Once the Substance Abuse Professional certifies that the employee does not present a risk to others in the work place and may return to work, the employee shall be allowed to return to work, subject to the disciplinary provisions of this policy, provided that employee passes a return-to-duty test and can fulfill the requirements of the job. Thereafter, such employee shall be subject to regular drug and alcohol testing at such intervals as shall be recommended by the Substance Abuse Professional. The employee is responsible for the cost of return-to-duty and follow-up testing.
- C. Any employee who shall fail to participate in and/or successfully complete a treatment program, including recommended after-care, as shall be recommended by the Substance Abuse Professional or shall thereafter test positive, shall be subject to immediate discharge.

SELF-REFERRAL FOR TREATMENT

- A. The Road Commission recognizes that an employee who is unfit for duty due to drug or alcohol abuse is a safety risk to themselves, their fellow employees and the motoring public. To this end, the Road Commission seeks to deter substance abuse through the implementation of this Policy. However, the Road Commission encourages its employees, who may have substance abuse problems, to voluntarily refer themselves to treatment programs. Said self-referral must occur prior to selection for testing or identification of a positive result.
- B. Employees are encouraged to seek treatment for drug or alcohol abuse and are offered cooperation and assistance under this Policy and/or applicable Contract benefits. Additionally, an employee who initiates his/her own treatment shall be exempt from the penalties of this Policy and/or the Collective Bargaining Agreement, subject to the terms and conditions set forth herein.
- C. In order to be exempt, the employee's self-referral must occur prior to any Road Commission-initiated random or reasonable cause testing and/or any other contract violations. The Self-Referral declaration by an employee at the time of random or reasonable cause testing or other contract violation occurrences shall not be allowed as an exemption from the implementation of discipline under this Policy or the Collective Bargaining Agreement.
- D. An employee who has referred himself for treatment shall be required to successfully complete a substance abuse rehabilitation program that includes a return to work drug and alcohol test prior to his return to work. In the event an employee tests negative, he will be allowed to return to work. If he tests positive, the employee must successfully complete a Road Commission-approved

substance abuse rehabilitation program including execution of a medical information waiver which gives the rehabilitation provider(s) the authorization to share confidential medical information so that the Road Commission can monitor the employee's progress in the treatment program.

REQUIRED NOTIFICATIONS

- A. **Convictions and Loss of Driving Privileges.** Employees shall notify their immediate supervisor within five (5) working days of any criminal drug statute conviction. Employees involved in equipment or vehicle operations shall notify their immediate supervisor within five (5) working days of any traffic violation conviction involving drugs or alcohol. Each employee who has a driver's license suspended, revoked, or cancelled, or who is disqualified from operating a motor vehicle for any period, shall notify the Road Commission of such suspension, revocation, cancellation or disqualification before the end of the business day following the day the employee received notice of the suspension, revocation, cancellation, or disqualification, but, in any event, prior to operating any Road Commission vehicle or equipment. Failure to do so will result in disciplinary action, up to and including termination from employment.
- B. **Prescription and Non-Prescription Medicine.** Any employee using a medication which his/her physician has advised the employee the use of such medication may affect the employee's ability to safely operate a motor vehicle, or the employee's ability to otherwise perform the duties of his/her position, shall promptly notify the Road Commission that he/she is currently using such medication.
- C. **Fitness for Duty/Call-in.** It shall be the policy of the Road Commission that any employees called to report for duty, during emergency or unscheduled operations, shall be personally asked and shall personally respond to the Road Commission's questions regarding their fitness for duty with respect to the consumption of drugs and/or alcohol. Further, the employee shall be required to notify the Road Commission's representative if at any time the employee is not fit to perform his/her duties for the Road Commission in a safe manner as such fitness may relate to the consumption of drugs and/or alcohol.

VIOLATIONS

In addition to any penalties mandated by the Department of Transportation, if an employee tests positive for illegal drugs and/or prohibited substances, or is under the influence (0.04% or above) of alcohol, the following are disciplinary steps that shall be taken:

- 1) **First Offense – Five (5) day suspension without pay;** upon completion of the five (5) day suspension and before an employee is allowed to return to work, he/she will submit to an evaluation by a Substance Abuse Professional and to a drug/alcohol test at the employee's expense. Upon approval of the Substance Abuse Professional and a negative test result, the employee will be allowed to

return to work.

- 2) Second Offense – Discharge.

DEFINITIONS

- A. **Under the influence** – An employee has been affected by a drug or alcohol, or a combination, in a manner that demonstrates a disregard for life or property or impairs the employee's ability to perform a given job or assignment. Symptoms of being under the influence of drugs or alcohol include, but are not restricted to, misbehavior, obvious impairment of physical or mental ability, slurred speech or difficulty in maintaining balance. Supervisors recommending testing of an employee for being under the influence shall document, in writing, their observations and the information they have which causes them to believe the employee is under the influence before the employee is sent to the appropriate place for testing.
- B. **Prohibited Substance** – Any drug or substance that is identified in 21 CFR 1308.11 Schedule I, any non-Schedule I drug or substance that is identified in the other Schedules in 21 CFR Part 1308 except when the use is pursuant to the instructions of a licensed medical practitioner who is familiar with the employee's medical history and has advised the employee that the substance will not adversely affect the employee's ability to safely operate a vehicle or equipment, or any drug or substance which has not been legally obtained
- C. **Drug Testing** – Any urine/blood or breath test conducted for the purpose of detecting the presence of a chemical substance in an individual.

Prepared For:
 Washtenaw County Road Commission
 Mike Livsey
 555 N Zeeb Rd.
 Ann Arbor, MI 48103-1556
 (734)761 - 1500
 Reference ID: Ultra Shift

Presented By:
 TRI COUNTY INTL TRUCKS
 Jeremy Kast
 3001 E HIGH ST
 JACKSON MI 49203
 (517)783-2721

****Updated to include, 16JJD-3 Lumbar driver seat,)*THB-Back-up Alarm, 16VCC-Orange Seta Belts, 08TMH-wiring and switch for strobe lights, 40SSC-Ext. Engine Warranty 48 months/100,000 miles****

Tri County International Trucks. Inc./State of Michigan DTMB Contract 071B6600122, Specification #3958 0172D for a new 2019 MY International HV 613 Truck Chassis per this proposal. Pricing includes all user specified option equipment costs and available discounts in effect as of date listed. Please note that the afforded pricing includes a 1% fee paid to the state of Michigan as required under this contract. Additional surcharge requirements as issued by the manufacturer may be applicable in the future.

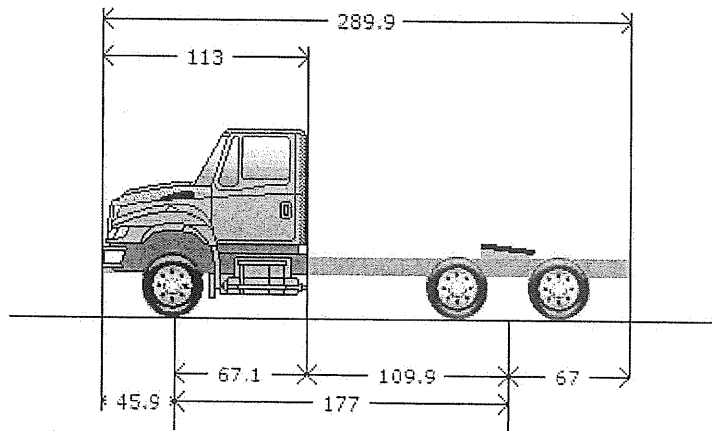

Model Profile
2020 HV613 SBA (HV613)

AXLE CONFIG:	6X4
APPLICATION:	Heavy Hauler Tractor
MISSION:	Requested GCWR: 120000. Calc. GVWR: 66000 Calc. Start / Grade Ability: 12.69% / 1.21% @ 55 MPH Calc. Geared Speed: 77.1 MPH
DIMENSION:	Wheelbase: 177.00, CA: 109.90, Axle to Frame: 67.00
ENGINE, DIESEL:	{International A26} EPA 2017, 450HP @ 1700 RPM, 1700 lb-ft Torque @ 1000 RPM, 2100 RPM Governed Speed, 450 Peak HP (Max)
TRANSMISSION, MANUAL:	{Eaton Fuller UltraShift+ FO-18E313A-MHP} 13-Speed Fully Automated Manual; with Aluminum Clutch Housing, Overdrive, Electronic Shift Controls, Electric Clutch Actuation, Air Range Shift, Internal Lube Oil Pump, Hill Start Aid
CLUTCH:	{Eaton Fuller ECA-1850} Two-Plate, Ceramic, 7-Spring with Pre-Damper, 15.5" Diameter, with Adjustment-Free Feature, 1850 lb-ft Torque Capacity
AXLE, FRONT NON-DRIVING:	{Meritor MFS-20-133A} Wide Track, I-Beam Type, 20,000-lb Capacity
AXLE, REAR, TANDEM:	{Meritor RT-46-164EH} Single Reduction, Standard Width, 46,000-lb Capacity, Driver Controlled Locking Differential in Forward-Rear and Rear-Rear Axle, 200 Wheel Ends Gear Ratio: 4.56
CAB:	Conventional
TIRE, FRONT:	(2) 445/65R22.5 Load Range L G296 MSA (GOODYEAR), 457 rev/mile, 68 MPH, All-Position
TIRE, REAR:	(8) 11R22.5 Load Range H HDR2 (CONTINENTAL), 491 rev/mile, 75 MPH, Drive

**SUSPENSION, REAR, AIR,
TANDEM:
PAINT:**

{Hendrickson PRIMAX EX} 46,000-lb Capacity, 55" Axle Spacing, 9.0" Ride Height,
with Shock Absorbers
Cab schematic 100WN
Location 1: 0311, Omaha Orange (Std)
Chassis schematic N/A

Code	Description	F/R Wt Tot Wt	
		(lbs)	(lbs)
HV61300	Base Chassis, Model HV613 SBA with 177.00 Wheelbase, 109.90 CA, and 67.00 Axle to Frame.	8297/4292	12589
1570	TOW HOOK, FRONT (2) Frame Mounted	8/0	8
1616	FRAME RAILS WITH TAPERED REAR	0/0	0
1AND	AXLE CONFIGURATION {Navistar} 6x4	0/0	0
	<u>Includes</u>		
	: DRIVESHAFT 1810 Series Transmission to Rear Axle		
	: INNER-AXLE SHAFT 1710 Series Forward Rear Axle to Rear Rear Axle		
	<u>Notes</u>		
	: Pricing may change if axle configuration is changed.		
1CAJ	FRAME RAILS Heat Treated Alloy Steel (120,000 PSI Yield); 10.866" x 3.622" x 0.433" (276.0mm x 92.0mm x 11.1mm); 456.0" (11582mm) Maximum OAL	144/321	465
1LLA	BUMPER, FRONT Steel, Swept Back	0/0	0
1WHN	WHEELBASE RANGE 152" (385cm) Through and Including 181" (460cm)	0/0	0
2ARY	AXLE, FRONT NON-DRIVING {Meritor MFS-20-133A} Wide Track, I-Beam Type, 20,000-lb Capacity	186/0	186
3AGA	SUSPENSION, FRONT, SPRING Parabolic Taper Leaf, Shackle Type, 20,000-lb Capacity, with Shock Absorbers	57/0	57
4092	BRAKE SYSTEM, AIR Dual System for Tractor Applications	1/0	1
4774	SPECIAL RATING, GAWR Provides Rear Tractor Brake Rating Equal to Axle Rating up to 23,000-lbs for Single Axles, 46,000-lbs for Tandem Axles, or 69,000-lb for Tridem	0/0	0
4AAU	BRAKE CHAMBERS, ADDITIONAL (2) {Bendix} Spring Brake Type; 30/30 SqIn	0/36	36
4AZV	AIR BRAKE ABS {Bendix AntiLock Brake System} Full Vehicle Wheel Control System (6-Channel; 6 Sensor/6 Modulator) with Automatic Traction Control	-10/-7	-17
4EBD	AIR DRYER {Wabco System Saver 1200} with Heater	10/8	18
4EXU	BRAKE CHAMBERS, REAR AXLE {Bendix EverSure} 30/30 Spring Brake	0/78	78
4JDE	BRAKES, FRONT, AIR DISC 22.5 Dia, Includes 27" Sq. In. Brake Chambers	43/0	43
4NDH	BRAKES, REAR, AIR CAM S-Cam; 16.5" x 8.625" Includes 30/30 Sq.In. Long Stroke Brake Chambers and Spring Actuated Parking Brake	0/100	100
4SPM	AIR COMPRESSOR {Bendix BA-921 Head Unload} 15.9 CFM Capacity, Single Cylinder	0/0	0
4VKC	AIR DRYER LOCATION Mounted Inside Left Rail, Back of Cab	0/0	0
4VKJ	AIR TANK LOCATION (2) Mounted Under Battery Box, Outside Left Rail, Back of Cab, Perpendicular to Rail	0/0	0
4WWZ	DRAIN VALVE (3) with Pull Chains for Air Tanks	0/0	0
4WZK	BRAKE PACKAGE, FRONT {Meritor EX225H2} Air, Disc Type, 22.5"	40/0	40

Code	Description	F/R Wt Tot Wt	
		(lbs)	(lbs)
5710	STEERING COLUMN Tilting and Telescoping	13/6	19
5CAW	STEERING WHEEL 4-Spoke; 18" Dia., Black	0/0	0
5PTB	STEERING GEAR (2) {Sheppard M100/M80} Dual Power	93/-8	85
6DDC	DRIVESHAFT SYSTEM SPL250XL Driveshaft and SPL170XL Interaxle Shaft in lieu of 1810 Driveshaft and 1710 Interaxle Shaft	0/0	0
7BEU	AFTERTREATMENT COVER Aluminum	0/0	0
7BKS	EXHAUST SYSTEM Single Horizontal Aftertreatment Device, Frame Mounted Right Side Under Cab; for Single Vertical Tail Pipe, Frame Mounted Right Side Back of Cab	53/24	77
7SDK	ENGINE COMPRESSION BRAKE by Jacobs; for N13/A26 Engines, with Selector Switch and On/Off Switch	48/1	49
7WAZ	TAIL PIPE (1) Turnback Type, Non-Bright, for Single Exhaust	0/0	0
7WBU	EXHAUST HEIGHT 11' 6"	2/0	2
7WDN	MUFFLER/TAIL PIPE GUARD (1) Non-Bright Aluminum	0/0	0
8000	ELECTRICAL SYSTEM 12-Volt, Standard Equipment	0/0	0
8518	CIGAR LIGHTER Includes Ash Cup	0/0	0
8695	SNOW SHIELD (2) Chrome; for Dual Air Horns	2/0	2
8GXJ	ALTERNATOR {Leece-Neville AVI160P2013} Brush Type; 12 Volt 160 Amp. Capacity, Pad Mount	0/0	0
8HXT	HORN, AIR (2) Single Tone, Chrome, Roof Mounted, with Lanyard Pull Cord	0/0	0
8MSH	BATTERY SYSTEM {Fleetrite} Maintenance-Free, (4) 12-Volt 2640CCA Total	26/26	52
8RMP	RADIO AM/FM/WB/Clock/3.5MM Auxiliary Input	2/0	2
8RMV	SPEAKERS (2) 6.5" Dual Cone Mounted in Doors	0/0	0
8THB	BACK-UP ALARM Electric, 102 dBA	0/3	3
8TMH	SWITCH, AUXILIARY Accessory Control; for Wiring in Roof, with Maximum of 20-amp Load with Switches In Instrument Panel	1/0	1
8VAY	HORN, ELECTRIC Disc Style	0/0	0
8VUL	BATTERY BOX Steel with Plastic Cover, 18" Wide, 2, 3, or 4 Battery Capacity, Mounted Left Side Back of Cab	0/0	0
8WPH	CLEARANCE/MARKER LIGHTS (5) {Truck Lite} Amber LED Lights, Flush Mounted on Cab or Sunshade	0/0	0
8WPZ	TEST EXTERIOR LIGHTS Pre-Trip Inspection will Cycle all Exterior Lamps Except Back-up Lights	0/0	0
8WRB	HEADLIGHTS ON W/WIPERS Headlights Will Automatically Turn on if Windshield Wipers are turned on	0/0	0
8WXB	HEADLIGHT WARNING BUZZER Sounds When Head Light Switch is on and Ignition Switch is in "Off" Position	0/0	0

<u>Code</u>	<u>Description</u>	<u>F/R Wt Tot Wt</u>	
		(lbs)	(lbs)
8WXG	STARTING MOTOR {Mitsubishi Electric Automotive America 105P} 12-Volt, with Soft-Start	0/0	0
8XAH	CIRCUIT BREAKERS Manual-Reset (Main Panel) SAE Type III with Trip Indicators, Replaces All Fuses	0/0	0
8XGT	TURN SIGNALS, FRONT Includes LED Side Turn Lights Mounted on Fender	0/0	0
8XHR	POWER SOURCE, ADDITIONAL Auxiliary Power Output (APO) & USB Port, Located in the Instrument Panel	0/0	0
9585	FENDER EXTENSIONS Rubber	0/0	0
9AAB	LOGOS EXTERIOR Model Badges	0/0	0
9AAE	LOGOS EXTERIOR, ENGINE Badges	0/0	0
9HBM	GRILLE Stationary, Chrome	0/0	0
9HBN	INSULATION, SPLASH PANELS for Sound Abatement	3/0	3
9WAC	BUG SCREEN Mounted Behind Grille	5/0	5
9WBK	FRONT END Tilting, Fiberglass, with Three Piece Construction Includes Long Hood	0/0	0
10060	PAINT SCHEMATIC, PT-1 Single Color, Design 100 <u>Includes</u> : PAINT SCHEMATIC ID LETTERS "WN"	0/0	0
10761	PAINT TYPE Base Coat/Clear Coat, 1-2 Tone	0/0	0
10HJA	FIFTH WHEEL, AIR SLIDE {Fontaine SL7LWB675024} 24" Slide, Cast Top Plate, 6.75" Above Top of Frame, Left Hand Release	7/504	511
10SLV	PROMOTIONAL PACKAGE Government Silver Package	0/0	0
10WCY	SAFETY TRIANGLES	8/4	12
10WPR	MUD FLAP HOLDER Spring Loaded, Painted Black; with Red and White Reflective Tape; Less Flaps	0/34	34
10WSX	MUD FLAPS, REAR Black Poly, with International Logo; Less Holders	0/8	8
10WWP	MUD-FLAPS, FRONT WHEELS (2) Rubber, Behind Front Wheels, Mounted on Fender Extension, for Tire Size 425/445	0/0	0
11MGP	CLUTCH {Eaton Fuller ECA-1850} Two-Plate, Ceramic, 7-Spring with Pre-Damper, 15.5" Diameter, with Adjustment-Free Feature, 1850 lb-ft Torque Capacity	0/0	0
12703	ANTI-FREEZE Red, Extended Life Coolant; To -40 Degrees F/ -40 Degrees C, Freeze Protection	0/0	0
12BEC	ENGINE, DIESEL {International A26} EPA 2017, 450HP @ 1700 RPM, 1700 lb-ft Torque @ 1000 RPM, 2100 RPM Governed Speed, 450 Peak HP (Max)	0/0	0
12THT	FAN DRIVE {Horton Drivemaster} Direct Drive Type, Two Speed with Residual Torque Device for Disengaged Fan Speed	0/0	0
12VBC	AIR CLEANER Single Element	0/0	0

<u>Code</u>	<u>Description</u>	<u>F/R Wt Tot Wt</u>	
		(lbs)	(lbs)
12VHC	FEDERAL EMISSIONS {International A26} EPA, OBD and GHG Certified for Calendar Year 2019	0/0	0
12WBR	FAN OVERRIDE Manual; with Electric Switch on Instrument Panel, (Fan On with Switch On)	0/0	0
12WTA	FAN DRIVE SPECIAL EFFECTS Fan Cooling Ring with Fan Shroud Effects, Engine Mounted	0/0	0
12WZE	EMISSION COMPLIANCE Federal, Does Not Comply with California Clean Air Idle Regulations	0/0	0
12XBD	RADIATOR Aluminum; Welded, Front to Back CrossFlow System, 1292 SqIn, 1008 SqIn CAC	0/0	0
12XBR	BLOCK HEATER, ENGINE {Phillips} 120V/1150W	4/0	4
13GXA	TRANSMISSION, MANUAL {Eaton Fuller UltraShift+ FO-18E313A-MHP} 13-Speed Fully Automated Manual; with Aluminum Clutch Housing, Overdrive, Electronic Shift Controls, Electric Clutch Actuation, Air Range Shift, Internal Lube Oil Pump, Hill Start Aid	177/63	240
13WET	TRANSMISSION SHIFT CONTROL for Column Mounted Stalk Shifter	0/0	0
13WGJ	OIL COOLER MANUAL TRANSMISSION Water to Oil Type Included in Radiator End Tank (REQUIRES TRANSMISSION LUBE PUMP)	0/0	0
13WLX	TRANSMISSION OIL {EmGard 40W} Synthetic; 22 thru 33.99 Pints	0/0	0
13XAR	PTO LOCATION Bottom of Transmission	0/0	0
14899	SUSPENSION AIR CONTROL VALVE Pressure Release Control In Cab	4/4	8
14HRC	AXLE, REAR, TANDEM {Meritor RT-46-164EH} Single Reduction, Standard Width, 46,000-lb Capacity, Driver Controlled Locking Differential in Forward-Rear and Rear-Rear Axle, 200 Wheel Ends . Gear Ratio: 4.56	0/2386	2386
14UNX	SUSPENSION, REAR, AIR, TANDEM {Hendrickson PRIMAAAX EX} 46,000-lb Capacity, 55" Axle Spacing, 9.0" Ride Height, with Shock Absorbers	0/685	685
14WBN	DIFF. SWITCH CONTROLS Two Independent Switches for Control Traction Differentials on Tandem Rear Axles, Mounted on Dash	1/0	1
14WMK	AXLE, REAR, LUBE {EmGard FE-75W-90} Synthetic Oil; 65 thru 89.99 Pints	0/0	0
15DYP	DEF TANK 9.5 U.S. Gal. 35.9L Capacity, Frame Mounted Outside Left Rail, Under Cab	0/0	0
15LKZ	FUEL/WATER SEPARATOR {Davco Fuel Pro 382} Includes Water-in-Fuel Sensor	2/0	2
15LNK	LOCATION FUEL/WATER SEPARATOR Mounted Above Right Rail, Back of Cab	0/0	0
15SJZ	FUEL TANK Top Draw, Non-Polished Aluminum, 26" Dia, 80 US Gal (303L), Mounted Left Side, Under Cab	-36/35	-1
16030	CAB Conventional	0/0	0
16BAM	AIR CONDITIONER with Integral Heater & Defroster	0/0	0

<u>Code</u>	<u>Description</u>	<u>F/R Wt Tot Wt</u>	
		(lbs)	(lbs)
16GDC	GAUGE CLUSTER Base Level; English with English Speedometer and Tachometer, for Air Brake Chassis, Includes Engine Coolant Temperature, Primary and Secondary Air Pressure, Fuel and DEF Gauges, Oil Pressure Gauge, Includes 3 Inch Monochromatic Text Display	0/0	0
16HKT	IP CLUSTER DISPLAY On Board Diagnostics Display of Fault Codes in Gauge Cluster	0/0	0
16JJD	SEAT, DRIVER {National 2000 195} Air Suspension, High Back with Integral Headrest, Cloth, Isolator, 3 Chamber Lumbar, 2 Position Front Cushion Adjust, -3 to +14 Degree Back Angle Adjust, Cushion and Back Bolsters	0/0	0
16SEE	GRAB HANDLE Chrome; Towel Bar Type with Anti-Slip Rubber Inserts; for Cab Entry Mounted Left Side Only at "B" Pillar	3/0	3
16SMR	SEAT, PASSENGER {National} Non Suspension, High Back with Integral Headrest, Cloth, with Fixed Back, with Under Seat Storage	25/16	41
16SNP	MIRRORS (2) Power Adjust, Thermostatically Controlled Heated Heads, Black Heads, Brackets and Arms, 7.55" x 14.1" Flat Glass, 7.48" x 6.77" Convex Glass Both Sides	0/0	0
16SNW	MIRROR, CONVEX, LOOK DOWN Right Side, Black, 6" x 10 1/4"	0/0	0
16VBX	CAB SOUND INSULATION Includes Dash Insulator Premium Floormat, and Sound Dampening Patches	10/0	10
16VCC	SEAT BELT All Orange; 1 to 3	0/0	0
16VKB	CAB INTERIOR TRIM Classic, for Day Cab <u>Includes</u> : CONSOLE, OVERHEAD Molded Plastic with Dual Storage Pockets, Retainer Nets and CB Radio Pocket; Located Above Driver and Passenger : DOME LIGHT, CAB Door Activated and Push On-Off at Light Lens, Timed Theater Dimming, Integral to Overhead Console, Center Mounted : SUN VISOR (2) Padded Vinyl; 2 Moveable (Front-to-Side) Primary Visors, Driver Side with Toll Ticket Strap	0/0	0
16WBY	ARM REST, RIGHT, DRIVER SEAT	3/0	3
16WJU	WINDOW, POWER (2) and Power Door Locks, Left and Right Doors, Includes Express Down Feature	5/0	5
16WSK	CAB REAR SUSPENSION Air Bag Type	0/0	0
16XJN	INSTRUMENT PANEL Flat Panel	0/0	0
16XWD	SUNSHADE, EXTERIOR Aerodynamic, Painted Roof Color; Includes Integral Clearance/Marker Lights	14/3	17
16ZBT	ACCESS, CAB Steel, Driver & Passenger Sides, Two Steps Per Door, for use with Regular and Extended Cabs	0/0	0
27DVD	WHEELS, FRONT {Accuride 29376} DISC; 22.5x13.00 Rims, Polished Aluminum, 10-Stud, 285.75mm BC, Hub-Piloted, Flanged Nut, with Steel Hubs	2/0	2
28DTJ	WHEELS, REAR {Maxion 90541} DUAL DISC; 22.5x8.25 Rims, Painted Steel, 2-Hand Hole, 10-Stud, 285.75mm BC, Hub-Piloted, Flanged Nut, with Steel Hubs	0/24	24

<u>Code</u>	<u>Description</u>	<u>F/R Wt Tot Wt</u>	
		(lbs)	(lbs)
29PAS	PAINT IDENTITY, REAR WHEELS Disc Rear Wheels; with Vendor Applied White Powder Coat Paint	0/0	0
29WLK	WHEEL BEARING, FRONT, LUBE {EmGard FE-75W-90} Synthetic Oil	0/0	0
60AAG	BDY INTG, REMOTE POWER MODULE Mounted Inside Cab behind Driver Seat; Up to 6 Outputs & 6 Inputs, Max. 20 amp. per Channel, Max. 80 amp Total (Includes 1 Switch Pack with Latched Switches)	0/0	0
7382135423	(8) TIRE, REAR 11R22.5 Load Range H HDR2 (CONTINENTAL), 491 rev/mile, 75 MPH, Drive	0/120	120
7702678113	(2) TIRE, FRONT 445/65R22.5 Load Range L G296 MSA (GOODYEAR), 457 rev/mile, 68 MPH, All-Position	170/0	170
810000	FIFTH WHEEL LOCATION On Rear Axle Centerline Cab schematic 100WN Location 1: 0311, Omaha Orange (Std) Chassis schematic N/A	0/0	0
Services Section:			
40127	WARRANTY Standard for HV513, HV613 Models, Effective with Vehicles Built July 1, 2017 or Later, CTS-2030A	0/0	0
40SSC	SRV CONTRACT, EXT ENGINE {Navistar} To 48-Month/100,000 Miles (160,000 km), Unlimited Hours, Includes Engine, Engine Electronics, Turbocharger, Water Pump and Fuel Injectors, for International A26 Engines	0/0	0
Total Component Weight:		9423/8766	18189
	State of Michigan MI Deal Fee Spec 3958-0172D	0/0	0
	D.O.T. Inspection, Saftey Kit, Mud Flaps	0/0	0
Total Goods Purchased:		0/0	0

The weight calculations included in this proposal are an estimate of future vehicle weight. The actual weight as manufactured may be different from the estimated weight. Navistar, Inc. shall not be liable for any consequences resulting from any differences between the estimated weight of a vehicle and the actual weight.

<u>Description</u>	(US DOLLAR)	<u>Price</u>
Total Factory List Price Including Options:		\$227,957.00
Total Goods Purchased:		\$1,297.60
Total Preparation And Delivery:		\$940.00
Total Freight:		\$2,200.00
Total Factory List Price Including Freight:		\$232,394.60
Less Customer Allowance:		(\$121,046.60)
Total Vehicle Price:		\$111,348.00
Total Sale Price:		\$111,348.00
Total Per Vehicle Sales Price:		\$111,348.00
Total Net Sales Excluding Taxes:		\$111,348.00
Michigan Title Fee	\$15.00	
Total License, Title:		\$15.00
Net Sales Price:		\$111,363.00

Payment for the chassis is due upon delivery of the cab/chassis to the end user or body company; which ever occurs first. If payment is not received in a timely manner additional floorplan(interest) costs may be charged to the end-user customer.

Please make all purchase orders and checks payable to:
Tri-County International Trucks, Inc.
5701 Wyoming Ave.
Dearborn, MI 48126

Please review this proposal very carefully. Your signature below indicates that you accept the specifications and payment terms, contained herein as written and that you are able to approve said specifications for order and payment terms. Please include this proposal number on all correspondence and purchase orders. This proposal contains in its entirety our offer to you for this purchase at the given dollar amount. No other offers, spec additions, warranties, or other additional items are made or implied. Other additional items may be available; contact your local dealer representative for further details.

Approved by Seller:

Accepted by Purchaser:

Salesman 11-29-2018

Official Title and Date

Firm or Business Name

Jeremy Kast

Authorized Signature

Authorized Signature and Date

TRI COUNTY INTL TRUCKS
3001 E HIGH ST
JACKSON MI 49203
(517)783-2721

This proposal is not binding upon the seller without Seller's Authorized Signature

Official Title and Date

The TOPS FET calculation is an estimate for reference purposes only. The seller or retailer is responsible for calculating and reporting/paying appropriate FET to the IRS.



December 3, 2018

Washtenaw County Road Commission
 555 N ZEEB RD
 Ann Arbor, Michigan 48103

Attention: Mike Livsey / Board of Directors

Thank you for this opportunity to quote a solution from Michigan CAT for your business needs. We are pleased to submit the following for your purchase consideration.

One (1) New 2019 CATERPILLAR Model: 950M HIGH LIFT Wheel Loader with the following factory and dealer options:

MACHINE	
950M HIGH LIFT WHEEL LOADER	464-2600
LINKAGE, HIGH LIFT	505-1553
HEAVY COUNTERWEIGHT, 1460KG	393-0072
AIR INLET STANDARD, RAIN CAP	365-0112
AXLES - FRONT LOCK / REAR OPEN	366-9903
HYDRAULICS - 2 VALVE - RIDE CONTROL	501-0400
HYDRAULIC OIL, STANDARD	366-9912
COLD STARTING AID (120V)	373-3911
HALOGEN LIGHTS	486-2311
WINDOWS, STANDARD	493-9615
STEERING WHEEL	384-7009
SINGLE AXIS LEVERS W / F-N-R	502-0336
3" SEAT BELT, W / INDICATOR	450-1592
MANUAL DIFF LOCK	384-7006
FILTRATION, STANDARD	505-1519
HEATED CAB TRIM	505-1512
PRODUCT LINK - CELLULAR PLE 641	434-0691
COOLING CORES, 9 FPI	364-9807
FAN, STANDARD	503-6412
ANTIFREEZE, -34C (-29F)	371-7064
RADIAL TIRES - 23.5R25 MX XHA2 * L3'S	373-4052
FENDERS	464-6672
NON-METALLIC HOOD	336-0000
SOUND SUPPRESSION	465-6576
AUTOLUBE - HIGH LIFT - INSTALLED	495-7498
ANTIFREEZE WINDSHIELD WASHER	0P-1939
FUEL ANTIFREEZE, -25C (-13F)	0P-3978
RADIO, CB (READY)	372-1603
LIGHTS, REVERSING STROBE	513-2458
WARNING BEACON	491-7467
CAT PAYLOAD MEASURE SYSTEM - PAYLOAD SOFTWARE	517-7123
POWER TRAIN GUARD	367-9027

1-888-MICH CAT
www.michiganecat.com

Novi . Shelby Twp. . Grand Rapids . Saginaw . Lansing
 Kalkaska . Brownstown Twp. Kalamazoo

QUICK COUPLER READY, HIGH LIFT	373-3904
FUSION QUICK COUPLER	349-5246
WORKTOOL'S LITERATURE	0P-4108
PROTECTION, CYLINDER ROD	0P-3940
RADIO, AM/FM / USB / MP3 BLUETOOTH	372-1600
96" WIDE FORK CARRIAGE GROUP	5207957
72" FORK TINES	5207979
HOOK, BLANK (FOR PLOW)	3175562
115" FUSION PERFORMANCE SERIES 4.0 YD3 BUCKET	5163431
INSTALL FLASHING STROBES	
BEET JUICE IN REAR TIRES	
HEATED MIRRORS	

MI DEAL SELL PRICE

\$289,672.00

MI DEAL CONTRACT # 071B7700084

WARRANTY

Standard Warranty:	Michigan CAT 12 Month, Unlimited Hour Standard Full Machine Warranty Service Agreement with 6 Months Mileage
Extended Warranty:	84 MONTH / 3500 HR POWERTRAIN (Tier 4)

F.O.B / TERMS: MI DEAL – NOVI MICHIGAN YARD – AVAILABLE END OF MARCH / 1ST WEEK OF APRIL 2019 IF ORDERED PRIOR TO DEC 15, 2018

TRADE: KOMATSU WA 380 s/n A52171

\$40,000

MICHIGAN CAT / MMC GUARANTEED BUY BACKS:

5 YEAR / 4000 HOURS	\$160,000
10 YEAR / 6000 HOURS	\$125,000

Michigan Cat / MMC will purchase the 950M back at either 5 Years or 10 Years at the WCRC's discretion, The machine must be in good operating condition, 50% tires, delivered back to Novi MI yard under the allotted hour range.

We believe the equipment as quoted will exceed your expectations. On behalf of Michigan CAT, thank you for the opportunity to supply Caterpillar machinery. This quotation is subject to machine availability and valid for 30 days, after which time we reserve the right to update the quote. If there are any questions, please do not hesitate to contact me.

Sincerely,



Mark Moran
Account Representative
Mark.Moran@MICHIGANCAT.com
248-568-5808

1-888-MICH CAT
www.michigancat.com

Novi . Shelby Twp. . Grand Rapids . Saginaw . Lansing
Kalkaska . Brownstown Twp. Kalamazoo



QUOTE

DOMINANT SYSTEMS

3850 Varsity Drive, Ann Arbor, MI 48108
t. 734-971-1210 f. 734-677-3321

Number DSCQ5979

Date Nov 6, 2018

Sold To	Ship To	Your Sales Rep
Washtenaw County Road Commissio 555 N Zeeb Rd Ann Arbor, MI 48103 Phone (734)761-1500 Fax (734)327-6642	Washtenaw County Road Commissio 555 N Zeeb Rd Ann Arbor, MI 48103 Phone (734)761-1500 Fax (734)327-6642	Terry

Here is the quote you requested.

Terms	P.O. Number	Ship Via
-------	-------------	----------

Line	Qty	Description	Unit Price	Ext. Price
1		MONTHLY MANAGED SERVICES FEES - INFRASTRUCTURE ONLY		
2	96	PC & Kiosk Monitoring, 1 device, 1 month	\$8.00	\$768.00
3	1	Infrastructure Managed Services, Network Components Only, 1 Month	\$8,710.00	\$8,710.00
4		<p><i>NOTE: Our Infrastructure Managed Services pricing is based on the price for CompleteCARE. For simple networks, the cost is 35% of the CompleteCARE price. For moderately complicated networks, the cost is 50% of the CompleteCARE price. For very complicated networks the cost is 65% of the cost of CompleteCARE.</i></p> <p><i>Guidelines for determining network complexity:</i> Simple Networks - 1-2 servers or VMs, under 20 users, no SQL or Exchange, 1 location Complicated Networks - 3-5 servers or VMs, under 50 users, 1 SQL or Exchange database, under 3 locations Very Complicated - over 5 servers or VMs, 50+ users, SAN or HCI-based servers, 3+ locations</p>		
5		<p><i>NOTE: See Quote # Q5978 for CompleCARE base rate of \$13,400 per month</i></p> <p>$\\$13,400 \times .65 = \\$8,710$</p>		
6		<p>INCLUDES:</p> <ol style="list-style-type: none"> 1. Unlimited 8:00am - 4:00pm telephone and/or onsite support for all your server and storage hardware, wireless access points, firewalls, data switches, power backup systems, and network devices. 2. 8x4x5 proactive monitoring of all significant network components including server and storage hardware, wireless access points, firewalls, data switches, power backup systems, and network devices. This may require that agent software be installed on the monitored device. 3. Regularly scheduled onsite visits to all sites. 4. Support for Windows Server, Linux, Hyper-V, and VMware. 5. Hardware diagnostics and basic repairs are included for all covered equipment. 6. Regularly scheduled testing of your data backup systems including a sample yearly full restore test to our hardware, subject to a 6TB limit per system. 7. Onsite support is available only to locations within 50 miles of our office in Ann Arbor, MI. 		

Due to recent changes in vendor return programs, all sales are final. If you wish to return a product, we will do our best to return it to our vendor for credit. If we are able to secure a return to our vendor, then we will accept a return from you. Quotes are valid for 15 days from date of issuance. Pricing does not include shipping/handling fees (if applicable) or installation services. Onsite installation services are available by appointment: please contact Terry or the Dominant Systems Help Desk for additional details and pricing. This price list is a quotation only and is not an order or offer to sell. No contract for sale will exist unless and until a purchase order has been issued by you and accepted by Dominant Systems Corp.

Line	Qty	Description	Unit Price	Ext. Price
------	-----	-------------	------------	------------

- 7 **SERVICE NOTES:**
1. Support for your phone system(s) are not included.
 2. After hours support (services performed outside of the hours of 8:00am to 4pm EST) is not included. These services are billable at our standard rates that are in effect at the time the service is performed. These rates may include a 50% overtime upcharge per hour.
 3. Support for your Office 365 server is included, however end-user support for MS Outlook is not included.
 4. Purchasing replacement hardware or software for components that fail is the responsibility of the Client. The diagnosis and installation of replacement components, however, is covered.
 5. Replacement of cabling is not included however the diagnosis of problems with cabling is included.
 6. Installation of new server and storage systems is not included, however upgrades to existing servers and storage systems is included. For example, if you have 5 servers and 1 storage system, and need to add a 6th server, installation of that server would be billable at our standard rates. Once installed, the number of billable installed systems would be increased by 1.
 7. Payments for third party support plans, maintenance plans, and subscriptions will be the responsibility of the Client.
 8. All hardware and software components must be less than 5 years old and be covered under the manufacturer's warranty (original or extended) to be considered fully supported. Any covered product that doesn't meet this specification will be supported on a best-effort basis.
 9. The cost of third party data recovery services, including the purchase of internet currency for ransom payments for data that has been hijacked, encrypted without authorization, or kidnapped is not included.
 10. Software development of any kind is not included.
 11. We recommend that you contract with a third party to perform yearly penetration testing of your systems. Payment for this service will be the Client's responsibility.
- 8 **PAYMENT NOTES:** Full payment is required monthly in advance. We reserve the right to withhold service if payment is not made by the 7th day of the month that it is due.
- 9 **GETTING STARTED:** To get this started we will need:
1. A signed copy of our managed services agreement.
 2. First and last month's payment in advance.

SubTotal	\$9,478.00
Tax	\$46.08
Total	\$9,524.08

Signature: _____ Date: _____

Please contact me if I can be of further assistance.

Due to recent changes in vendor return programs, all sales are final. If you wish to return a product, we will do our best to return it to our vendor for credit. If we are able to secure a return to our vendor, then we will accept a return from you. Quotes are valid for 15 days from date of issuance. Pricing does not include shipping/handling fees (if applicable) or installation services. Onsite installation services are available by appointment: please contact Terry or the Dominant Systems Help Desk for additional details and pricing. This price list is a quotation only and is not an order or offer to sell. No contract for sale will exist unless and until a purchase order has been issued by you and accepted by Dominant Systems Corp.

TRUCK & TRAILER *Specialties, Inc.*

1200 Victory Drive | Howell, MI 48843 | www.ttspec.com | Ph: (517) 552-3855 | Fx: (517) 552-3666

December 10, 2018

Washtenaw County Road Commission
Attn: Mike Livsey
555 North Zeeb Road, Ann Arbor, MI 48103



State Contract Hyperlink No. 071B5500010

Equipment Quotation utilizing the state contract awarded to Truck & Trailer Specialties, Inc.

Supply Monroe 32' custom trailer model 32IAA-A trailer including the following:

Approximately 32' in length
I-beam construction of mainframe with 24" kingpin setting
Kingpin plate is ½"
Kingpin plate to be 47" from ground to top
½" web reinforcing

The rear tandem axles on the trailer shall be a Ridewell air suspension and shall include the following:

Integrated trailer air-ride suspension
25K capacity weld-on style hangers with weld collars
Flush-mount shocks
71.5" track axle
Straight spindle
30/30 chambers
Auto-slacks
16.5 x 7 brakes
The brake system shall include Q-Plus brake system with proper S-cams, drums and brakes to fit the Q-plus system

The forward axle set at 9' spread distance will be a Ridewell air suspension with a Ridewell four dual airbag under beam lift assembly and shall include the following:

25K capacity weld-on style hangers with weld collars
Flush-mount shocks
71.5" track axle
Straight spindle
30/30 chambers
Auto-slacks
16.5 x 7 brakes - Q Plus type
Rear axles will include Wabco ABS system 4S2M and shall comply with all FMVSS standards
9' spread axle will not include an ABS system

Install Liquid pumping system including the following:

Hypro pump model 9307 including drive motor and coupler
Bulk fill kit located at the center of the trailer with all necessary shutoffs
2" spraybar with 15 fan nozzles and boom busters on each end of the spraybar
Booms are stainless steel construction

Install Two (2) Ace Roto Mold Chloride Tank with hooks and skid assembly including the following:

Tanks are 3250 gallon (6500 total capacity)

TRUCK & TRAILER *Specialties, Inc.*

1200 Victory Drive | Howell, MI 48843 | www.ttspec.com | Ph: (517) 552-3855 | Fx: (517) 552-3666

Tanks are 1.9 specific gravity
Tanks include a baffle wall in each tank
Tanks include a dome with a bolt-on reinforcement bracket
Ladder mounted between the tanks

Install Single-lane Dust Control System including the following:

Trailer to be equipped with a Groeneveld pneumatic powered lube system, mounted near center of trailer
Holland two-speed landing gear

Full-width rear bumper includes the following:

Ride under protection ICC bumper
Recessed standard STT and marker lighting
Rear mounted one amber and one green flashers
Full-width rubber flap at the rear

Galvanized trailer frame as per specifications
Dust control plumbing kit with all necessary shut-offs
Plumbing kit includes fill stations as per spec
Pricing includes delivery to Washtenaw County
Pricing includes title work

Install Customer Lighting & Electrical including the following:

Two (2) ECCO (mo. ED3706AG) LED green/amber split flashers mounted one each side-facing with shield mounted mid-way on the sides of the trailer
Two (2) ECCO 6" A/G flashers at the rear
One (1) Federal Signal 252650-02SC on SS stand mounted at the rear, tank height for 360 visibility

Above supplied and installed pricing: \$106,134.00 ea.

Payment Terms: Net 30. Pricing effective for 45 days.

FOB: Washtenaw CRC

Delivery: 210-270 days ARO

Thank you for the opportunity to quote.

Respectfully submitted by,
Jon Luea/Brian Bouwman

TRUCK & TRAILER *Specialties, Inc.*

1200 Victory Drive | Howell, MI 48843 | www.ttspec.com | Ph: (517) 552-3855 | Fx: (517) 552-3666

December 10, 2018

Washtenaw County Road Commission
Attn: Mike Livsey
555 North Zeeb Road, Ann Arbor, MI 48103



State Contract Hyperlink No. 071B5500010

Equipment Quotation utilizing the state contract awarded to Truck & Trailer Specialties, Inc.

Install Tractor Wet Kit including the following:

489 PTO Chelsea to fit manual transmission with approx. 125% PTO
Parker 3.94 CID gear pump directly coupled to the PTO
Rexroth 3m4-12 control valve including the following:
 Unloader section for gear pump main relief at 2500 psi
 DA Hoist air section 2000 psi pressure limit for hoist up and 500 for hoist down with dump valve
 SA EPC 15 gallon for dust control with pressure limit 2000 psi
 SA EPC for Low boy 2500 psi
 16" SS valve enclosure
Control console in cab includes a VM-8 detented controller for hoist
Slimline back of cab hyd tank with return filter, 50 gallons
Ball valve shut-off on tanks
AW32 hydraulic oil
9' jumper hoses at the rear include a 1" pressure line for dump, 3/4" return line and 3/4" pressure line for the low boy/dust control trailer operation
County to supply Hydraulic couplers
Spring-mount back of cab to hold hoses

Install County-supplied Dickey John Control Point with new wiring harness, liquid driver and needed cables for boom valve and flowmeter

Install Customer Lighting & Electrical including the following:

Chassis switches for: PTO, strobes, air tailgate & pin-lock
Two (2) ECCO (mo. ED3706AG) LED green/amber split flashers mounted in grille (separate switch)
One (1) Whelen (mo. MC-16) Century 12VDC mini lightbar with amber dome & amber LED's mounted on truck cab with aluminum riser and weather pack
Two (2) 4" ECCO (mo. E92006) LED spreader work lights rear-facing mounted on cab
OEM STT/BU lights at rear
Timed Flaming River battery disconnect
7-pin trailer plug flush-mounted at leftside rear, centerpin used for trailer ABS
7-pin trailer plug flush-mounted at rear to operate strobes, valves & tailgate locks

Install Minimizer Spray Control Fenders for tandem chassis including the following:

Minimizer (mo. Min900B) tandem fender kit - black
Plastic fender (mo. B4578BTPA) mounting kit
All necessary supports and brackets

Install Frame Reinforcement at rear of Chassis behind the fifth wheel including the following:

Box rear of frame with 3/4" plate

TRUCK & TRAILER *Specialties, Inc.*

1200 Victory Drive | Howell, MI 48843 | www.ttspec.com | Ph: (517) 552-3855 | Fx: (517) 552-3666

Paint as necessary

Install serrated bar grating frame cover from the back of the hyd tank to the front of the 5th wheel plate, paint black

Install Buyers 24x28x18" Aluminum step box on street side

Above installed pricing: \$18,210.00

Chassis requirements to be confirmed at time of order:

Exhaust under curbside door

PTO enabled transmission

6 Chassis auxiliary switches

Payment Terms: Net 30. Pricing effective for 45 days.

FOB: Washtenaw CRC

Delivery: 45-60 days after receiving chassis

Thank you for the opportunity to quote.

Respectfully submitted by,
Jon Luea/Brian Bouwman

VOUCHER #

10328

WASHTENAW COUNTY
BOARD OF ROAD COMMISSIONERS
ANN ARBOR, MICHIGAN

DATE December 11, 2018

WARRANT # _____

AMOUNT \$ 288,863.74

ACCT. CODE 20

TO: WASHTENAW COUNTY ROAD COMMISSION

ITEMS	DISCOUNT	CLASSIFICATION	GROSS AMT.
20104600.800000			
PAYROLL FOR December 12, 2018			\$ 288,863.74
GROSS PAYROLL \$ 294,069.46			
<u>A.C.H.</u>			
Payroll Direct Deposit \$ 190,480.84			
Deferred Comp \$ 8,371.00			

It is hereby certified that the above account is true and correct and that no part of it has been paid.

To the County Clerk:
The within account has been carefully checked and audited. You are hereby directed to draw your warrant upon the County Treasurer for the above amount payable from the County Road Fund.

CONTROLLER

CHAIRMAN

The above account approved by:

MEMBER

MANAGING - DIRECTOR & DEPUTY CLERK OF THE BOARD

BOARD OF COUNTY ROAD COMMISSIONERS

VOUCHER # 10329

WASHTENAW COUNTY
BOARD OF ROAD COMMISSIONERS

ANN ARBOR, MICHIGAN

DATE December 11, 2018

WARRANT # _____

TO: WASHTENAW COUNTY ROAD COMMISSION

AMOUNT \$2,833,180.26

ACCT. CODE 20

ITEMS	DISCOUNT	CLASSIFICATION	GROSS AMT.
20104600.800000			\$ 2,811,375.66
FICA/MEDICARE			\$ 21,804.60
ACCOUNTS PAYABLE FOR December 12, 2018			

It is hereby certified that the above account is true and correct and that no part of it has been paid.

To the County Clerk:
The within account has been carefully checked and audited. You are hereby directed to draw your warrant upon the County Treasurer for the above amount payable from the County Road Fund.

CONTROLLER

The above account approved by:

CHAIRMAN

MEMBER

MANAGING - DIRECTOR & DEPUTY CLERK OF BOARD

BOARD OF COUNTY ROAD COMMISSIONERS

Date 12/11/2018
Time 07:46:15

Washtenaw County Road Commission
AP - Check Register

Page 1 of 4
balkwellt

----- Check -----		----- Vendor -----		Check
Number	Date	Number	Name	Amount
78440	12/12/2018	ADALAP	ADAM LAPE	160.00
78441	12/12/2018	AGGIND	AGGREGATE INDUSTRIES, MGMT INC	139,249.49
78442	12/12/2018	AIRADV	AIR ADVANTAGE LLC	75.00
78443	12/12/2018	AIRGAS	AIRGAS USA, LLC	75.90
78444	12/12/2018	AISCON	AIS CONSTRUCTION EQUIPMENT	1,679.49
78445	12/12/2018	AMDHYD	AM-DYN-IC FLUID POWER INC	242.12
78446	12/12/2018	ANNBAN	ANN ARBOR STATE BANK	14,951.83
78447	12/12/2018	AAWELD	ANN ARBOR WELDING SUPPLY	57.14
78448	12/12/2018	ARBINS	ARBOR INSPECTION SERVICES LLC	920.00
78449	12/12/2018	BEARES	BEAVER RESEARCH COMPANY	947.28
78450	12/12/2018	BLUECR	BLUE CROSS BLUE SHIELD OF MI	264,200.00
78451	12/12/2018	BRECRO	BRETT CROUSE	100.00
78452	12/12/2018	BREINC	BREWERS INC	362.50
78453	12/12/2018	BRIDAV	BRIAN DAVIS	80.00
78454	12/12/2018	C&MWIR	C & M WIRE ROPE & SUPPLY CO.	702.07
78455	12/12/2018	CADASP	CADILLAC ASPHALT LLC	Void
78456	12/12/2018	CADASP	CADILLAC ASPHALT LLC	578,445.77
78457	12/12/2018	CARGAB	CARRIER & GABLE INC	974.00
78458	12/12/2018	SUNSER	CBTS	3,366.63
78459	12/12/2018	CHESTA	CHELSEA STATE BANK	45,713.90
78460	12/12/2018	CITCHE	CITY OF CHELSEA	323.84
78461	12/12/2018	COMCAS	COMCAST	574.03
78462	12/12/2018	COMMUN	COMPASS MINERALS	3,151.09
78463	12/12/2018	CONMCK	CONLIN, MCKENNEY & PHILBRICK	3,744.00
78464	12/12/2018	CONENG	CONSUMERS ENERGY	300.51
78465	12/12/2018	CONTRA	CONTRACTORS CONNECTION INC	374.75
78466	12/12/2018	CONREN	CONTRACTORS RENTAL	7,958.18
78467	12/12/2018	CTTMTU	CTT/MTU	430.00
78468	12/12/2018	CURBRO	CURTIS BROCHUE	255.00
78469	12/12/2018	DKTRUC	D & K TRUCK COMPANY	1,385.24
78470	12/12/2018	DAVTEC	DAVCO TECHNOLOGY LLC	2,107.00
78471	12/12/2018	DELDR	DELUX DRAPERY & SHADE CO	874.40
78472	12/12/2018	DETED2	DETROIT EDISON	11,184.99
78473	12/12/2018	DETSAL	DETROIT SALT COMPANY LLC	32,903.70
78474	12/12/2018	DOMSYS	DOMINANT SYSTEMS	1,719.70
78475	12/12/2018	DTEENE	DTE ENERGY	6,087.95
78476	12/12/2018	EASJOR	EJ USA, INC	2,034.40
78477	12/12/2018	ELETER	ELECTRICAL TERMINAL SERVICE	1,388.36
78478	12/12/2018	ELESEC	ELECTRONIC SECURITY SYSTEMS	7,140.00
78479	12/12/2018	EMIKIZ	EMILY KIZER	80.00
78480	12/12/2018	ENZCLE	ENZO'S CLEANING SOLUTIONS	2,947.50
78481	12/12/2018	FERENT	FERGUSON ENTERPRISES INC	262.44
78482	12/12/2018	FISTHO	FISHBECK THOMPSON CARR & HUBER	19,918.06
78483	12/12/2018	FLEPRI	FLEET PRIDE	Void
78484	12/12/2018	FLEPRI	FLEET PRIDE	6,639.74
78485	12/12/2018	FLINEW	FLINT NEW HOLLAND INC	116.82
78486	12/12/2018	FOSBLU	FOSTER BLUE WATER OIL	1,184.14
78487	12/12/2018	FOUBUI	FOUNDATION BUILDING MATERIALS	255.36
78488	12/12/2018	FRETOW	FREEDOM TOWNSHIP	3,470.51

Date 12/11/2018
Time 07:46:15

Washtenaw County Road Commission
AP - Check Register

Page 2 of 4
balkwellt

----- Check -----		----- Vendor -----		Check
Number	Date	Number	Name	Amount
78489	12/12/2018	GMENTE	G & M ENTERPRISES LTD	2,500.00
78490	12/12/2018	GALLOU	GALLOUP	10.08
78491	12/12/2018	GANLLC	GANCO LLC	4,566.25
78492	12/12/2018	GIBCAB	GIBRALTAR GLOBAL LLC	3,033.32
78493	12/12/2018	GRAING	GRAINGER INC	719.34
78494	12/12/2018	GREALA	GREAT LAKES ENGINEERING GROUP	385.00
78495	12/12/2018	GREGAW	GREGORY GAW	127.19
78496	12/12/2018	GROUP0	GROUP 31 SUPPLY	1,658.95
78497	12/12/2018	HEAEQU	HEALTH EQUITY	7,203.68
78498	12/12/2018	HECHER	HECTOR HERNANDEZ	1,500.00
78499	12/12/2018	HUBSUP	HUBBARD SUPPLY CO	817.67
78500	12/12/2018	HUBROT	HUBBELL, ROTH, & CLARK INC	29,744.96
78501	12/12/2018	INTBLU	INTEGRAL BLUE	2,631.54
78502	12/12/2018	IROIND	IRONHAWK INDUSTRIAL	3,757.88
78503	12/12/2018	JSTREE	J'S TREE TRIMMING & REMOVAL IN	6,000.00
78504	12/12/2018	JACTRU	JACKSON TRUCK SERVICE INC	128.79
78505	12/12/2018	JAMTEC	JAMAR TECHNOLOGIES INC	267.48
78506	12/12/2018	JEFMAN	JEFFREY MANN	221.00
78507	12/12/2018	JJINK	JJ JINKLEHEIMER & CO	2,225.00
78508	12/12/2018	KBKLAN	KBK LANDSCAPING	7,650.00
78509	12/12/2018	KELGIN	KELLY GINGRAS	160.00
78510	12/12/2018	KOORAD	KOOL RADIATOR SERVICE	2,394.00
78511	12/12/2018	LAWPRO	LAWSON PRODUCTS INC	340.10
78512	12/12/2018	LEIGEO	LEICA GEOSYSTEMS, INC.	200.00
78513	12/12/2018	LENFUE	LENAWEE FUELS INC	9,395.36
78514	12/12/2018	LIGCAR	LIGHTHOUSE CAR WASH	120.00
78515	12/12/2018	LOWES0	LOWES	1,084.09
78516	12/12/2018	MKTRUC	M & K TRUCK CENTERS	88.95
78517	12/12/2018	MADELE	MADISON ELECTRIC CO	517.86
78518	12/12/2018	KLETRU	MANCHESTER TRUE VALUE	85.07
78519	12/12/2018	MATTES	MATERIALS TESTING	15,230.49
78520	12/12/2018	MENINC	MENARD INC	120.31
78521	12/12/2018	MICBER	MICHAEL J BERNBECK	80.77
78522	12/12/2018	MICKLU	MICHAEL R KLUCK & ASSOCIATES	2,801.47
78523	12/12/2018	MICCAT	MICHIGAN CAT	7,867.55
78524	12/12/2018	MIDMAI	MIDWEST MAINTENANCE SERVICES	3,970.97
78525	12/12/2018	MOTIND	MOTION INDUSTRIES INC	35.60
78526	12/12/2018	MSCIND	MSC INDUSTRIAL SUPPLY CO INC	174.00
78527	12/12/2018	MSDSON	MSDSONLINE INC.	380.00
78528	12/12/2018	MERS00	MUNICIPAL EMPLOYEES RETIREMENT	578,710.00
78529	12/12/2018	NAGPAV	NAGLE PAVING	4,014.11
78530	12/12/2018	NAPAUT	NAPA AUTOPARTS	214.89
78531	12/12/2018	NAPLAW	NAPOLEON LAWN & LEISURE INC.	280.74
78532	12/12/2018	NICVAN	NICOLE PETERSON	20.00
78533	12/12/2018	OCCHEA	OCCUPATIONAL HEALTH CENTERS OF	220.50
78534	12/12/2018	OFFDEP	OFFICE DEPOT INC	1,022.96
78535	12/12/2018	ORCHIL	ORCHARD HILTZ & MCCLIMENT INC	2,148.81
78536	12/12/2018	ORIDIA	ORIGIN DIAGNOSTICS LLC	785.00
78537	12/12/2018	OSBASS	OSBURN ASSOCIATES INC	7,132.26

Date 12/11/2018
Time 07:46:15

Washtenaw County Road Commission
AP - Check Register

Page 3 of 4
balkwellt

----- Check -----		----- Vendor -----		Check
Number	Date	Number	Name	Amount
78538	12/12/2018	OSCLAR	OSCAR W LARSON COMPANY	8,571.08
78539	12/12/2018	PAMFAI	PAM FAIRCHILD	2,430.59
78540	12/12/2018	PAUSCH	PAUL SCHNEIDER	65.03
78541	12/12/2018	PENTOO	PENNSYLVANIA TOOL	257.00
78542	12/12/2018	WCRC--	PETTY CASH	325.85
78543	12/12/2018	PRITEC	PRINT-TECH INC	376.86
78544	12/12/2018	PUCPRO	PUCK PROPERTIES	7,500.00
78545	12/12/2018	QUFIRE	QUALITY FIRE SERVICES	817.00
78546	12/12/2018	RSCONT	R S CONTRACTING INC	38,244.65
78547	12/12/2018	RECYCL	RECYCLE ANN ARBOR	370.00
78548	12/12/2018	REPSE	REPUBLIC SERVICES #241	239.20
78549	12/12/2018	RICOH0	RICOH USA, INC	2,095.75
78550	12/12/2018	RMDHOL	RMD HOLDINGS LTD	22,693.66
78551	12/12/2018	OAKCOU	ROAD COMMISSION FOR OAKLAND CO	238.38
78552	12/12/2018	DETMAR	RODZINA INDUSTRIES INC	15.45
78553	12/12/2018	ROWDIN	ROWERDINK INC.	855.00
78554	12/12/2018	RSENGI	RS ENGINEERING, LLC	25,648.87
78555	12/12/2018	SAFAUT	SAFELITE AUTO GLASS	175.00
78556	12/12/2018	SAFKLE	SAFETY KLEEN CORPORATION	953.42
78557	12/12/2018	SALTRU	SALENBIEN TRUCKING	20,570.00
78558	12/12/2018	SCITOW	SCIO TOWNSHIP	453.01
78559	12/12/2018	SHATWP	SHARON TOWNSHIP	1,823.70
78560	12/12/2018	SHRTIR	SHRADER TIRE	16,255.15
78561	12/12/2018	SME000	SME	10,833.62
78562	12/12/2018	SOIMAT	SOIL AND MATERIALS ENGINEERS	325.00
78563	12/12/2018	SOMATO	SOMAT ENGINEERING	7,612.55
78564	12/12/2018	STAHAR	STADIUM HARDWARE	5.47
78565	12/12/2018	STAINS	STANDARD INSURANCE COMPANY	8,614.14
78566	12/12/2018	MIDEPT	STATE OF MICHIGAN	594,262.01
78567	12/12/2018	STEHEA	STEELE HEATING & COOLING INC	316.57
78568	12/12/2018	STEGIB	STEVEN GIBSON	47.30
78569	12/12/2018	STOMIC	STONECO OF MICHIGAN	1,812.45
78570	12/12/2018	SUBCHE	SUBURBAN CHEVROLET	1,586.69
78571	12/12/2018	TETTEC	TETRA TECH, INC.	10,664.08
78572	12/12/2018	TIDENT	TIDY MRO ENTERPRISES	1,476.86
78573	12/12/2018	TPCTRA	TPC TRAINING	3,300.00
78574	12/12/2018	TRETIR	TREDROC TIRE	3,683.91
78575	12/12/2018	TRITRU	TRI-COUNTY INTERNATIONAL	187.03
78576	12/12/2018	TRUSPE	TRUCK & TRAILER SPECIALTIES	4,681.49
78577	12/12/2018	TUVRHE	TUV RHEINLAND INDUSTRIAL	11,801.16
78578	12/12/2018	ARRUNI	UNIFIRST	534.60
78579	12/12/2018	UOFMEN	UNIVERSITY OF MICHIGAN	250.00
78580	12/12/2018	USICEC	US ICE CORP	750.00
78581	12/12/2018	USTRAC	US TRACKWORKS LLC	10,000.00
78582	12/12/2018	VANOBR	VANSTON/OB'RIEN INC	3,524.47
78583	12/12/2018	VARPRO	VARIPRO	11,572.81
78584	12/12/2018	VERWIR	VERIZON WIRELESS	3,616.58
78585	12/12/2018	VILMAN	VILLAGE OF MANCHESTER	58.03
78586	12/12/2018	WADTRI	WADE-TRIM	76,561.98

(47)

Date 12/11/2018
Time 07:46:15

Washtenaw County Road Commission
AP - Check Register

Page 4 of 4
balkwellt

----- Check -----		----- Vendor -----		Check
Number	Date	Number	Name	Amount
78587	12/12/2018	REGDEE	WASHTENAW COUNTY REGISTER	2,340.00
78588	12/12/2018	WASMAN	WASTE MANAGEMENT	116.46
78589	12/12/2018	WELTRU	WELLER TRUCK PARTS LLC	26.91
78590	12/12/2018	WESWAT	WEST WATER & SEWER	2,861.18
78591	12/12/2018	WJONEI	WJ ONEIL COMPANY	1,118.84
Report Total				2,811,375.66



Washtenaw County Board of County Road Commissioners

555 N. Zeeb Road ❖ Ann Arbor, Michigan 48103
(734) 761-1500

*** 2019 Board Meeting Schedule ***

WASHTENAW COUNTY BOARD OF ROAD COMMISSIONERS' 2019 BOARD MEETING SCHEDULE

(Meetings are held every 1st and 3rd Tuesday of the month, unless otherwise noted.)

Meeting Time: 1:00p.m.

January 2, 2019 (Wednesday)	July 16, 2019
January 15, 2019	August 6, 2019
February 5, 2019	August 20, 2019
February 19, 2019	September 3, 2019
March 5, 2019	September 17, 2019
March 19, 2019	October 1, 2019
April 2, 2019	October 15, 2019
April 16, 2019	November 5, 2019
May 7, 2019	November 19, 2019
May 21, 2019	December 3, 2019
June 4, 2019	December 17, 2019
June 18, 2019	January 7, 2020
July 2, 2019	

The Officers for 2019 & 2020 are as follows:

Chair:
Vice-Chair:
Member:

Committee Assignments for 2019 & 2020 are as follows:

Washtenaw County Parks Commission:
Washtenaw Area Transportation Study:
Michigan Townships Association:

Board meeting minutes of the Board of County Road Commissioners are on file and available for inspection at the Washtenaw County Road Commission offices located at 555 N. Zeeb Road, Ann Arbor Michigan 48103, or on the WCRC website at: www.wcroads.org

Every six months, Board meeting minutes are also filed with the Washtenaw County Clerk/Register of Deed, located at 200 N. Main Street, Suite 120, Ann Arbor, Michigan 48107.

Posted:



Washtenaw County Board of County Road Commissioners
 555 N. Zeeb Road
 Ann Arbor, Michigan 48103
 (734) 761-1500

**~ BOARD WORKING SESSIONS
 Through December 2019 ~**

**The Board of County Road Commissioners
 will hold a series of Working Sessions
 on the following dates
 at 9:00 a.m.**

<u>Date</u>	<u>Subject</u>
January 15	Communications & IT Updates
February 19	Pavement Warranties
March 19	Permits Rules & Regulations
April 16.....	2019 First Quarter Budget Review
May 16.....	TBD
June 18	Signal Network & Other Technologies
July 16.....	2019 Second Quarter Budget Review
August 20	Employee Attraction & Retention
September 17	TBD
October 15.....	Asset Management/SAW Update
November 19	2019 Final Budget Review/2020 Preliminary Budget
December 17	TBD

**Sheryl Soderholm Siddall
 Deputy Clerk**

Posted:



WASHTENAW COUNTY ROAD COMMISSION

TOWNSHIP/STAFF REPORT – December 18, 2018

For the period of November 26, 2018 thru December 9, 2018

TOWNSHIP REPORT

OPERATIONS REPORT

MAINTENANCE

Scraping of gravel roads and patching of paved roads were performed throughout the county. In addition, the following maintenance activities were performed in individual townships:

ANN ARBOR TOWNSHIP

- Limestone Patch – Country Club Drive, Ford Road: 28 tons
- Roadside Debris – Plymouth Road

AUGUSTA TOWNSHIP

- Limestone Patch – Arkona Road, Hitchingham Road, Judd Road, Liss Road, Pitman Road, Tuttle Hill Road: 236 tons

BRIDGEWATER TOWNSHIP

- Limestone Patch – Allen Road, Braun Road: 47 tons
- McCollum Road Limestone Resurfacing – 4,241 tons

DEXTER TOWNSHIP

- Cut Trees – Dexter-Pinckney Road, Dexter Town Hall Road, Hankerd Road, North Lake Orchard Drive
- Fallen Trees – Toma Road, Quigley Road
- Gravel Patch – Toma
- Limestone Patch – Colby Road, Dancer Road, Island Lake Road, Stofer Road, Toma Road: 50 tons

FREEDOM TOWNSHIP

- Fallen Trees – Ellsworth Road
- Gravel Patch – Ernst Road, Hieber Road: 43 tons
- Limestone Patch – Ernst Road, Hieber Road: 16 tons

LIMA TOWNSHIP

- Boom Mow – Scio Church Road
- Brush Removal – N Dancer Road, Dexter-Chelsea Road, Scio Church Road
- Fallen Trees – Old US-12 Road, Trinkle Road
- Gravel Patch – Beach Road, Dancer Road: 12 tons
- Limestone Patch – Guenther Road, Trinkle Road: 33 tons
- Tree Removal – Dexter-Chelsea Border-to-Border Trail

LODI TOWNSHIP

- Limestone Patch – Ellsworth Road, Zeeb Road: 53 tons

LYNDON TOWNSHIP

- Cut Trees – Hadley Road, Loveland Road, Waterloo Road
- Gravel Patch – Boyce Road, Bush Road, Goodband Road, Joslin Lake Road: 3 tons
- Limestone Patch – Boyce Road: 4 tons

MANCHESTER TOWNSHIP

- Boom Mow – Herman Road
- Culvert Replacement – Mull Road
- Drainage and Backslopes – Bowens Road, Hudson Road, Lemm Road, Schleweis Road, Van Tuyle Road
- Fallen Trees – Bowens Road, Parr Road, Scully Road
- Gravel Patch – Herman Road, Mull Road, Sharon Hollow Road, Wellwood Road: 73 tons
- Limestone Patch – Herman Road, Mull Road, Sharon Hollow Road: 25 tons
- Roadside Debris – Noggles Road
- Shoulder Maintenance – Kirk Road, Schleweis Road, Sharon Hollow Road

NORTHFIELD TOWNSHIP

- Fallen Trees – North Territorial Road, Seven Mile Road
- Limestone Patch – Butternut Road, Earhart Road, Eight Mile Road, Five Mile Road, Garfield Drive, Hellner Road, Jay Street, Jennings Road, Joy Road, Kearney Road, Lincoln Drive, N Maple Road, Northfield Church Road, Phlox Drive, Ridge Road, Rushton Road, Six Mile Road, Spencer Road: 466 tons

PITTSFIELD TOWNSHIP

- Cleaned Culvert – State Road
- Limestone Patch – Bemis Road, Iris Lane, Merritt Road, Morgan Road, Munger Road, Poppy Lane, Thomas Road, Warner Road: 126 tons
- Limestone Patch Shoulders – Ellsworth Road, N Maple Street, Maple Road, Moon Road, Old State Road, State Road, Stoneridge Drive, Textile Road, Windmill Way: 31 tons
- Roadside Debris – State Road
- Street Sweeping – Bicentennial Parkway, E Horizons Court, Lohr Lake Drive, Mallard Cove Drive, McCormick Drive, Silo Ridge Drive, Silver Maple Drive, Vineyard Avenue, White Swan Lane, Wilson Road

SALEM TOWNSHIP

- Culvert Replacement – Six Mile Road
- Fallen Tree – Six Mile Road
- Limestone Patch – Brookville Road, Chubb Road, Dixboro Road, Five Mile Road, Napier Road, Six Mile Road: 110 tons
- Limestone Patch Shoulders – Eight Mile Road, Six Mile Road: 75 tons

SALINE TOWNSHIP

- Ditching – Arkona Road, Macon Road
- Limestone Patch – Arkona Road, Dell Road, Feldkamp Road, Macon Road, Willow Road: 170 tons

SCIO TOWNSHIP

- Berming – Wagner Road
- Boom Mow – Liberty Road
- Gravel Patch – E Delhi Road: 10 tons
- Limestone Patch – Park Road, Staebler Road: 12 tons

SHARON TOWNSHIP

- Boom Mow – Kothe Road
- Drainage and Backslopes – Sylvan Road
- Fallen Trees – Heim Road
- Gravel Patch – Below Road, Pleasant Lake Road, Sharon Hollow Road, Washburne Road: 104 tons
- Limestone Patch – Below Road, Pleasant Lake Road, Sharon Hollow Road, Smythe Road, Washburne Road, Wingate Road: 59 tons

SUPERIOR TOWNSHIP

- Drainage and Backslopes – Barrington Drive, Prospect Road
- Limestone Patch – Albert Drive, Cherry Hill Road, Gale Road, Gotfredson Road: 237 tons
- Limestone Patch Shoulders – W Clark Road: 28 tons

SYLVAN TOWNSHIP

- Boom Mow – Scio Church Road, Kalmbach Road
- Brush Removal – Bush Road
- Fallen Trees – Cavanaugh Lake Road
- Gravel Patch – Bush Road: 4 tons
- Limestone Patch – Bush Road: 4 tons

WEBSTER TOWNSHIP

- Gravel Patch – Base Lake Drive, Daly Road, Mast Road, Northfield Church Road: 25 tons
- Limestone Patch – Barker Road, Merrill Road: 15 tons

YORK TOWNSHIP

- Ditching Project – Maple Road
- Drainage and Backslopes – Maple Road, Willow Road
- Limestone Patch – Arkona Road, Crane Road, Day Road, Fosdick Road, Hack Road, Judd Road, Maple Road, Mooreville Road, Petersburg Road, Willow Road: 262 tons

YPSILANTI TOWNSHIP

- Drainage and Backslopes – George Avenue
- Limestone Patch – Bemis Road, Ellis Road, Merritt Road, Morgan Road, Munger Road: 294 tons
- Limestone Patch Shoulders – Textile Road, Whittaker Road: 27 tons
- Roadside Debris – Allen Avenue, E Clark Road, Ford Boulevard, Holmes Road, Ridge Road

NESC REPORT

Warranty work and additional equipment installation by contractors is on-going. Working with contractors for additional equipment installation.

WINTER MAINTENANCE

- Crews Responded – 4 times
- Total Salt Used – 947 tons
- Total Abrasives Used – 95 tons
- Total Brine Used – 1,755 gallons

SHOP REPORT

Shop Repairs

- Tires Repaired – 4 tires
- New Tire Installation – 5
- Vehicles Serviced – 2
- Vehicles Serviced by Suburban Chevrolet – 4
- Work Orders Completed – 38

Equipment Repair

Note: Performed several hydraulic repairs

- Truck 305 – Replaced the tarp motor
- Truck 325 – Replaced the radiator, charged air cooler, batteries and rear torque rods
- Truck 373 – Completed rear brake replacement
- Truck 380 – Replaced the flight chain
- Truck 383 – Replaced the engine wiring harness and two rear brake chambers

BUILDING & GROUNDS REPORT

Yard One

- Janitorial
- Recycling
- Swept garage floor
- Repaired garage lights
- Remodeling in Foreman's office
- Installed new door closer in shop
- Winter maintenance
- Repaired cove molding in office

Yard Two

- Repaired and replaced lights in the office and outside

Yard Four

- Cleaned drains
- Installed bollards around pole barn sand salt barn
- Made cover for brine pump

NESC

- Repaired power washer
- Installed dry erase board

MEETINGS ATTENDED

11/27 J. Harmon and E. Kizer attended the Homeland Security Task Force meeting held at the Emergency Operations Center in Ann Arbor.